

Logic Controllers

Contents

Logic Controllers

- Product Overview 34.1-1
- ELC Controllers / Modules 34.1-2
- ELC Graphic Panels 34.1-8
- ELC Software 34.1-11
- ELC Accessories 34.1-12

EZ Intelligent Relays

- Product Family Overview 34.2-1
- EZ 500/700/800/EZD Intelligent Relays 34.2-2
- EZD Controller I/O Modules 34.2-9
- EZ/EZD Expansion Modules 34.2-10
- EZ/EZD Communication Modules 34.2-12
- EZ Software 34.2-13
- EZ/EZD Power Supplies 34.2-14
- EZ/EZD Accessories 34.2-15

Specifications

See Eaton's Cutler-Hammer Product Specification Guide on enclosed CD-ROM:

- 1995 CSI Format: Section 16906
- 2004 CSI Format: Section 26 09 05

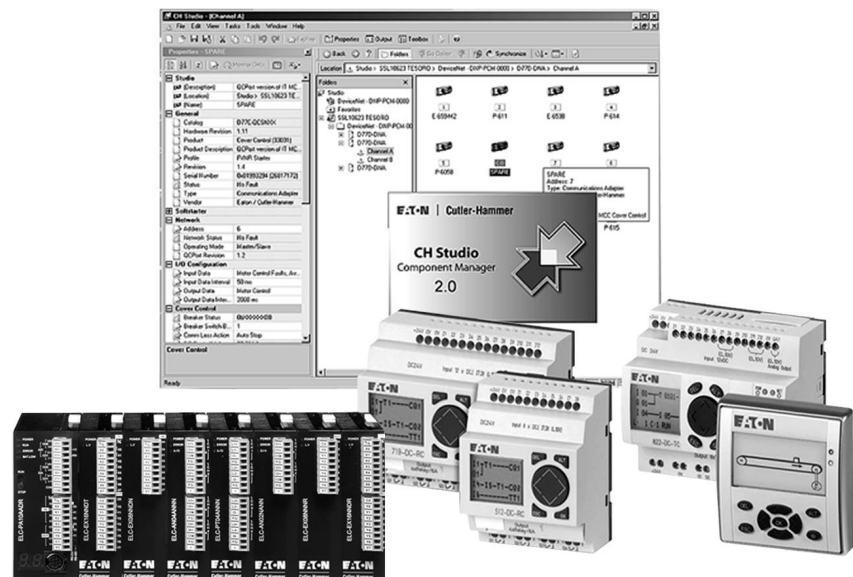

ELC Programmable Logic Controllers and EZ Intelligent Relays

This page intentionally left blank.

ELC Overview

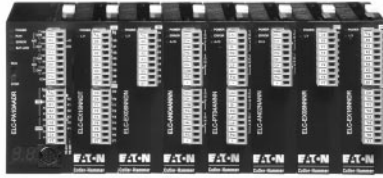

ELC Modules

The Eaton Logic Controller (ELC) is our latest offering into the PLC (Programmable Logic Controller) marketplace. Using the latest technology, this reduced sized ELC with its abundant module selection will provide a "Just Right" concept of providing only what you want for the price you need.

- **Size** — Providing large PLC features/functions in a small 1" package. ELC is 1/3 the size of past PLC products (D50 model), offering identical and even a larger feature set than the D50. ELC can provide 46 I/O in the space that a D50 could provide 14 I/O.
- **Flexibility** — ELC controllers can handle I/O counts from 10 I/O to 256 I/O using the same controller. ELC eliminates the process of counting I/O and deciding which controller to use, ELC is the only one needed. ELC modules come in many flavors of I/O from modules containing 4 in / 4 out to modules containing 8 in / 8 out. ELC is not a rack-based system — it simply mounts to a DIN rail. Add modules by simply snapping them into the mating connectors and closing the attached locks.
- **Large PLC Features** — ELC has the feature set of larger PLCs, from its multiple communications ports, remote I/O ability, data storage, high speed counter, high speed pulse outputs, interrupts, timer resolution to 1 ms, PID, plus much more.
- **Software** — ELCSoft, the software, configures the entire line of ELC controllers. Economically priced, it programs in standard ladder logic and sequential function chart programming. It will aid in knowing what registers are in use and what modules are attached to the ELC. It monitors the runtime application, allows forcing (except basic), and entering values. Software wizards aid programming of remote I/O, standard communications and PIDs.
- **Power of One** — ELC communicates easily to Eaton type MVX Adjustable Frequency Drives eliminating the need to operate drives by analog voltage/current or digital I/O. ELC can access all of the parameters in the MVX by serial communications. ELC communicates to *IT* I/O through the Modbus TCP gateway. This allows ELC to control the *IT* I/O if local control is desired. This will also allow *IT* I/O to be used in communicating MCC applications where the ELC can be either a DeviceNet™, PROFIBUS®, or Modbus®TCP communicating MCC. ELC communicates to PowerNet™ Modbus products, allowing ELC connectivity to Switchgear and PowerNet applications.

ELC Controllers

The ELC family offers four styles of controllers. These controllers offer combinations of the following features:

- High speed pulse capture and high speed pulse output on all controllers.
- Interrupts.
- Broad module selection ac/dc in, relay/transistor out.
- Wide selection of analog in, out, combined, thermocouple or RTD Platinum.
- Over 200 instructions to choose from: Floating point math, communications, hex, decimal, octal, BCD, ASCII conversion, 1, 4, 8, 16, 32, bit manipulations, logical, block move, block compare, retentive data storage, time base from clock/calendar.
- Two Modbus (ASCII or RTU) serial ports: 1 slave only, 1 master/slave.
- Network communications on Modbus TCP, DeviceNet and PROFIBUS.
- ELC controller can be wired for remote I/O communications (except the PB model).

ELC Controllers/Modules

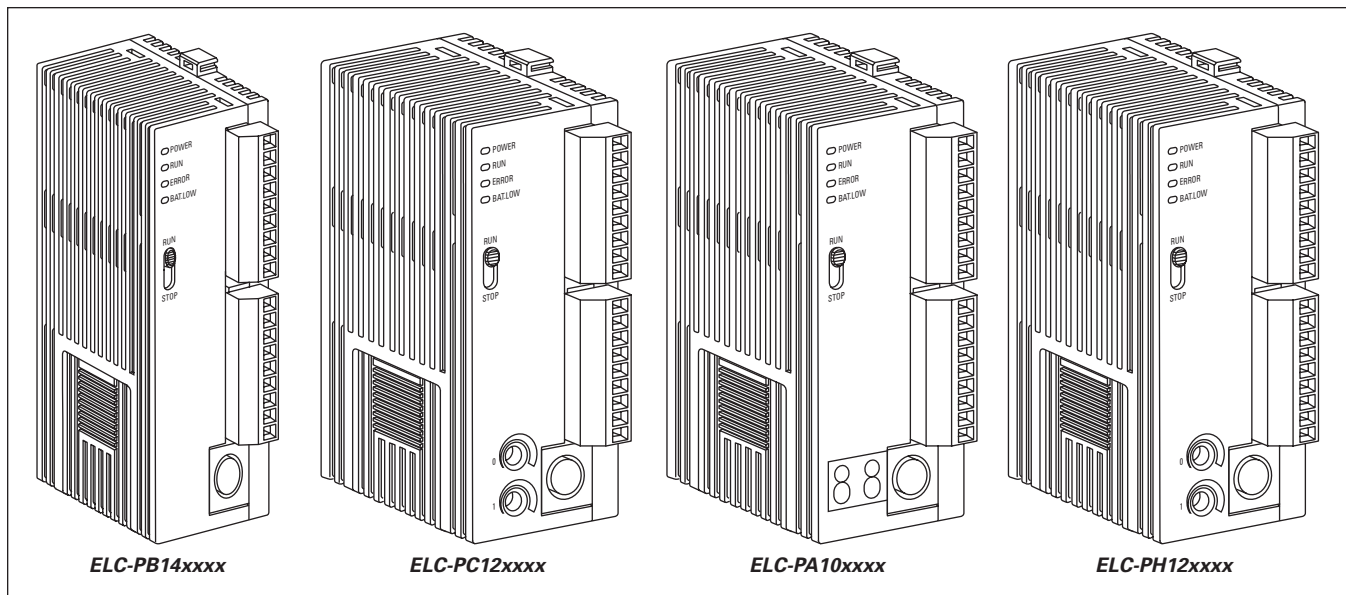

Figure 34.1-1. ELC Controllers

Table 34.1-1. ELC Controller Features

Items	ELC-PB14xxxx	ELC-PC12xxxx	ELC-PA10xxxx	ELC-PH12xxxx
Dimensions WxHxD in Inches (mm)	1.00 x 3.54 x 2.36 (25.2 x 90 x 60)	1.74 x 3.54 x 2.36 (37.4 x 90 x 60)		
Maximum I/O	256 (128 In / 128 Out) Any number of modules			
I/O Type	14 (8 In / 6 Out) – Digital	12 (8 In / 4 Out – Digital)	10 (4 In / 2 Out Digital, 2 In / 2 Out Analog)	12 (8 In / 4 Out – Digital)
Execution Speed	Basic commands - 2µ seconds minimum			
Program Language	Boolean + Ladder Logic + SFC			
Program Capacity	3792 Steps	7920 Steps		
Data Memory Capacity (bits)	1280 Bits	4096 Bits		
Data Memory Capacity (words)	744 Words	5000 Words		
Index Registers	2 Words	8 Words		
File Memory Capacity	—	1600 Words		
Commands	32 Basic / 107 Advanced	32 Basic / 168 Advanced		
Floating Point	Yes	Yes		
SFC Commands	128 Steps	1024 Steps		
Timers	128 (1 – 100 ms)	256 (1 – 100 ms)		
Counters	128 (16 Bit / 32 Bit / Up/Down)	250 (16 Bit / 32 Bit / Up/Down)		
High Speed Counters	4 (14 modes) 10 K Maximum	4 (14 Modes) 20 kHz for PA/PC 100 kHz for PH		
Pulse Output	2 channels 10 kHz Maximum	2 channels, 40 kHz Max for PC/PA, 100 kHz for PH		
Master Control Loop	8 Loops			
Subroutines	64 Subroutines	256 Subroutines		
Interrupts	6	15 (External / Time Base / HS CNTR / Comm.)		
Real-time Clock/Calendar	—	Built-in		
Specialty Expansions Modules	8 (Analog In / Analog Out / TC / PT) Modules do not count in total I/O			
Serial Ports	2 (1 – RS-232, 1 – RS-485)			
Special Features	—	2 Potentiometers	2 7-Segment Displays	2 Potentiometers

Dimensions

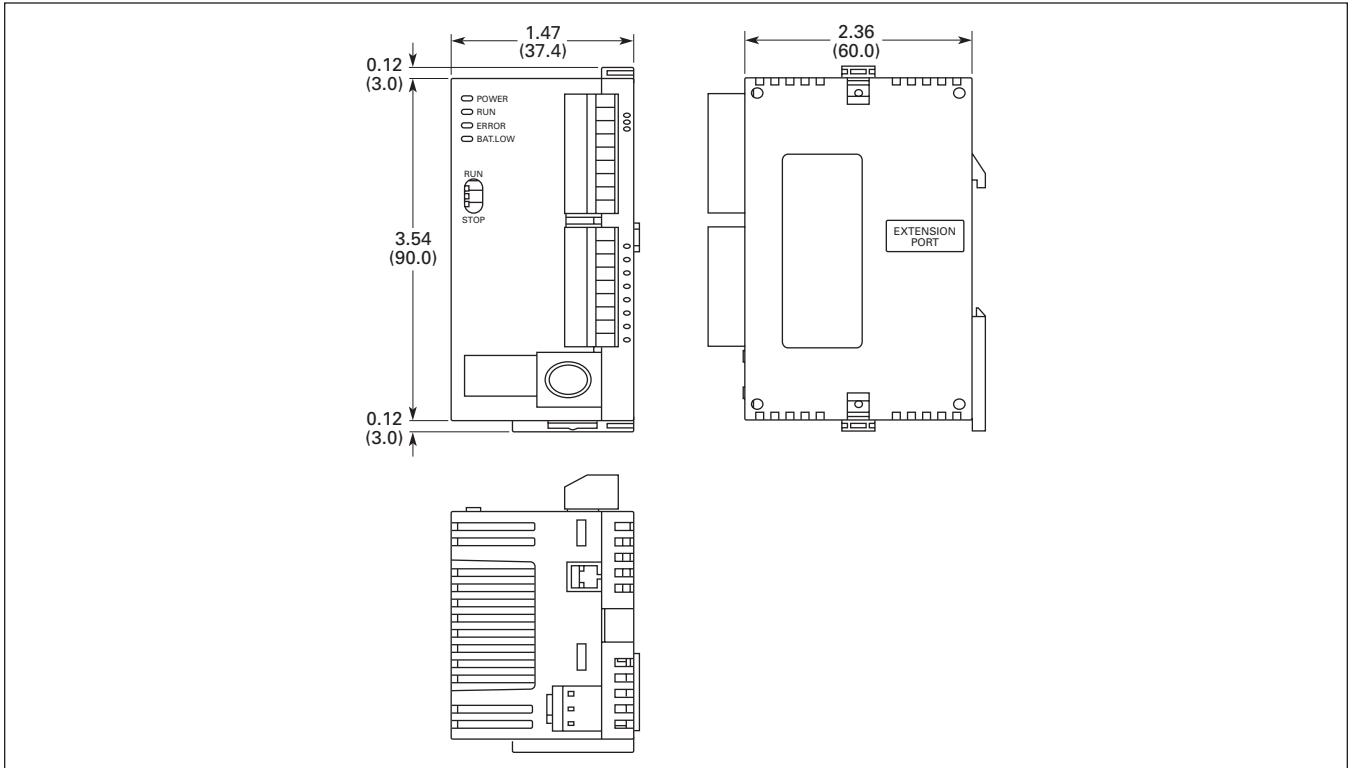

Figure 34.1-2. ELC-PA10, ELC-PC12 and ELC-PH12 Controllers — Approximate Dimensions in Inches (mm)

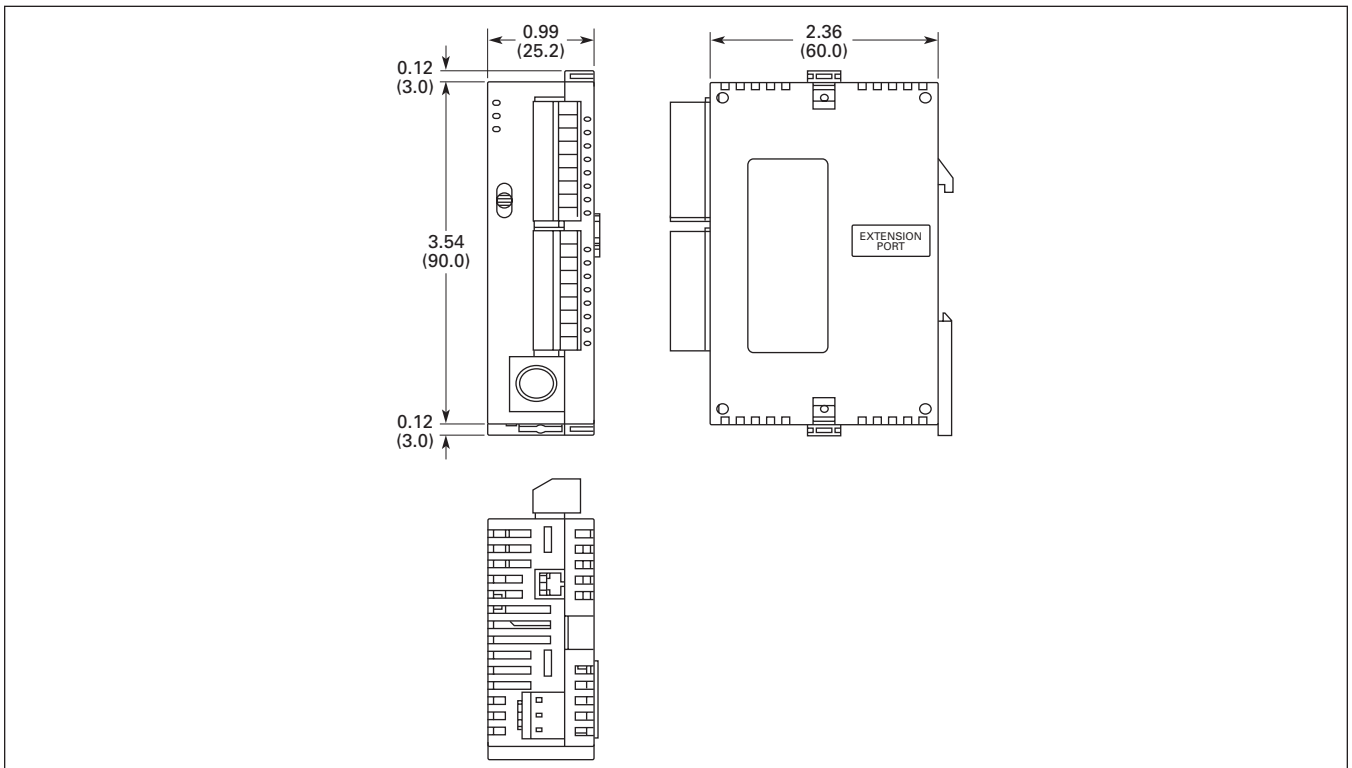

Figure 34.1-3. ELC-PB14 Controllers — Approximate Dimensions in Inches (mm)

ELC Modules

ELC Expansion Modules

ELC expansion modules provide the correct amount of I/O for application solutions. Choose 4, 8 or 16 I/O. Any number of expansion modules can be added to the ELC processor to create 256 I/O (128 Inputs and 128 Outputs maximum).

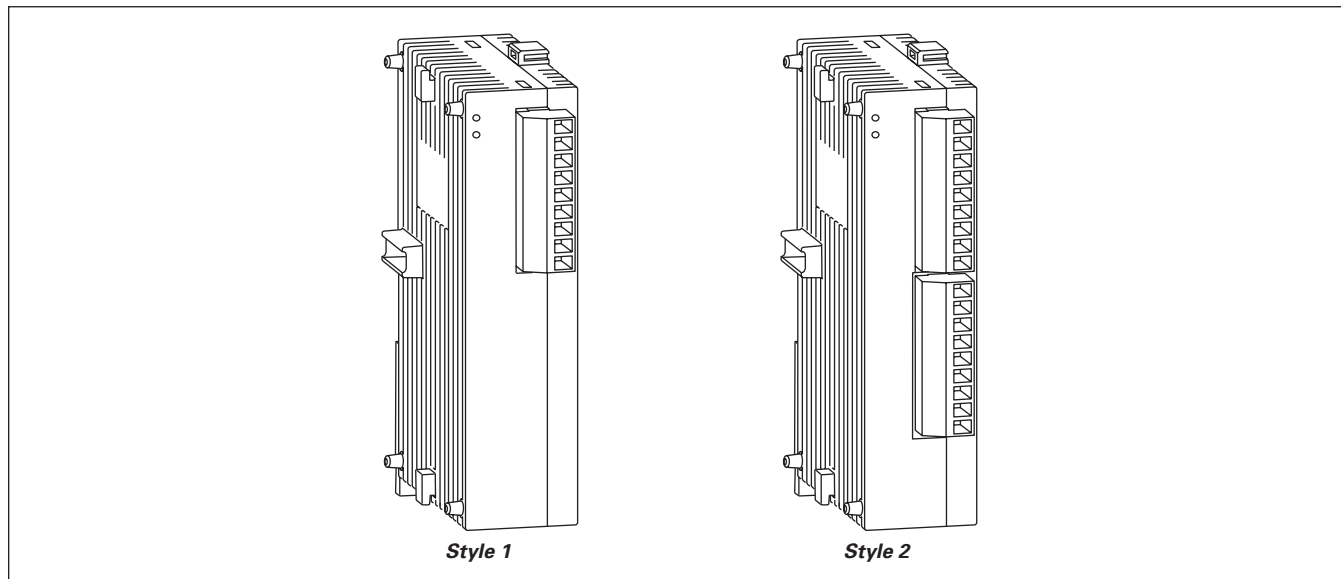

Figure 34.1-4. ELC Expansion Modules

Table 34.1-2. ELC Expansion Module Features

Model	Style	Inputs		Outputs	
		Points	Type	Points	Type
Dimensions W x H x D in Inches (mm)		0.99 x 3.54 x 2.36 (25.2 x 90 x 60)			
ELC-EX08NNAN — ac IN	1	8	120 Vac	0	—
ELC-EX08NNDN — dc IN	1	8	dc Sink or Source	0	—
ELC-EX08NNNR — Relay OUT	1	0	—	8	Relay
ELC-EX08NNNT — Transistor OUT	1	0	—	8	Transistor
ELC-EX06NNNI — High Current Relay OUT	2	0	—	6	Relay (6 Amps)
ELC-EX08NNDR — IN/OUT Combo	2	4	dc Sink or Source	4	Relay
ELC-EX16NNDR — IN/OUT Combo	2	8	dc Sink or Source	8	Relay
ELC-EX08NNDT — IN/OUT Combo	2	4	dc Sink or Source	4	Transistor
ELC-EX16NNDT — IN/OUT Combo	2	8	dc Sink or Source	8	Transistor

ELC Specialty Modules

In addition to the expansion I/O, specialty modules like Analog In, Analog Out, Platinum Temperature, Thermocouple, DeviceNet, PROFIBUS DP and Switch Module, etc. can be added. Use the ELC-485APTR to easily connect to the RS-485 port of MVX drive, ELC controllers and other devices.

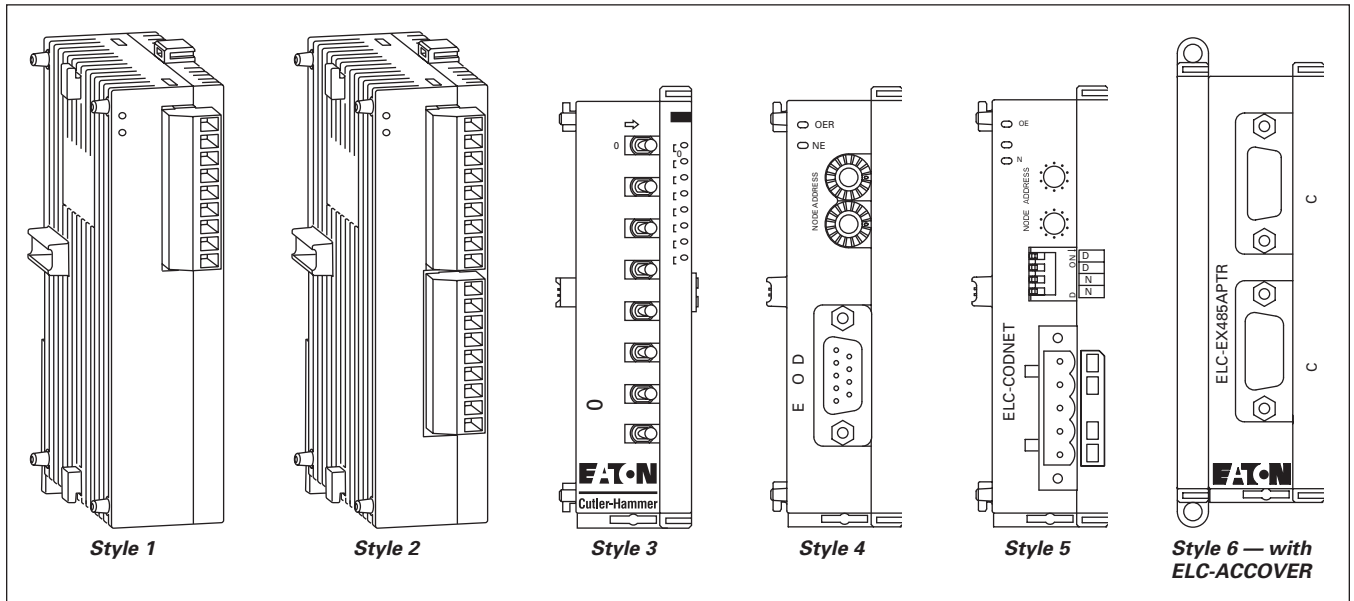
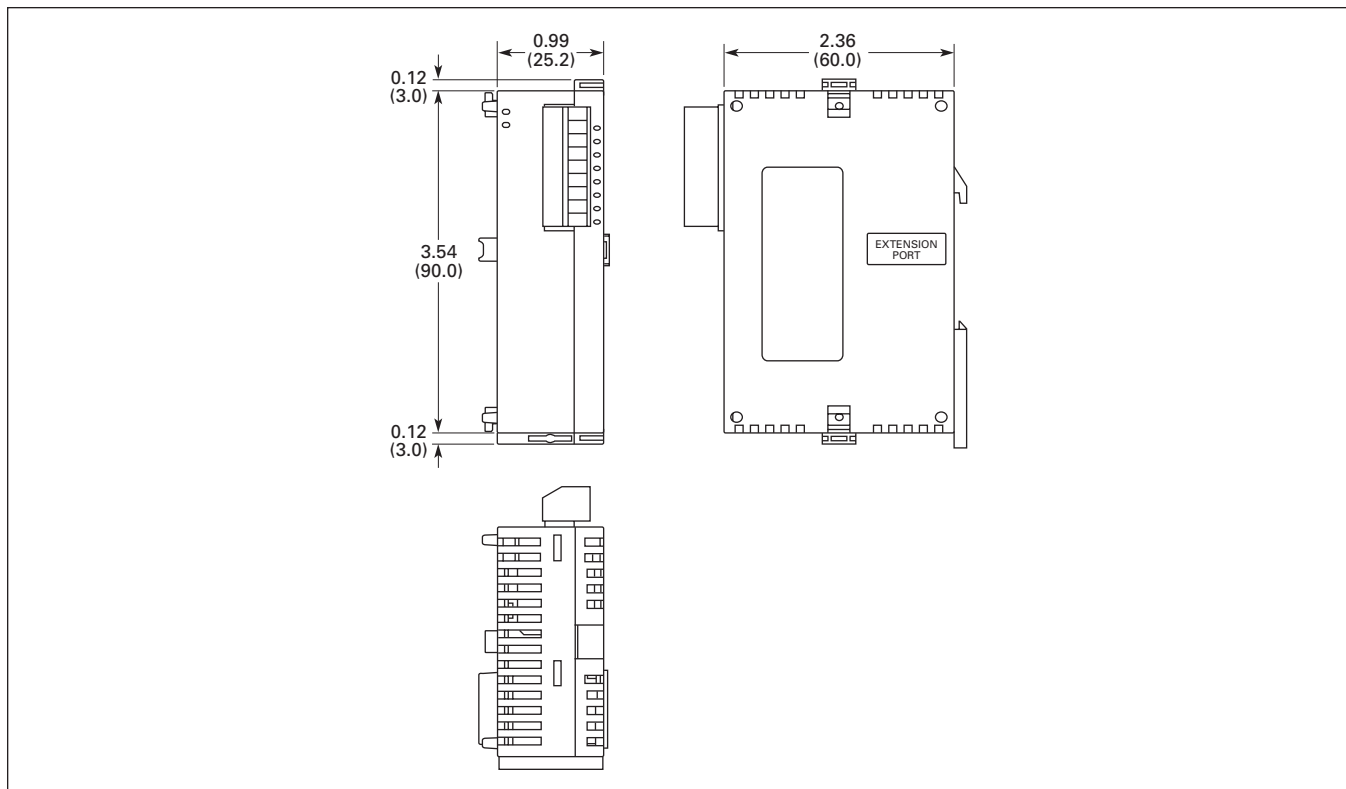

Figure 34.1-5. ELC Specialty Expansion Modules

Table 34.1-3. ELC Expansion Module Features

Model	Power	Style	Inputs		Outputs	
			Points	Type	Points	Type
Dimensions W x H x D in Inches (mm)			0.99 x 3.54 x 2.36 (25.2 x 90 x 60)			
ELC-AN02NANN — Analog OUT	24 Vdc	1	0	-20 mA~20 mA -10 V ~ +10 V	2 (12 Bits) 4 (12 Bits)	0~20 mA, 4~20 mA 0V ~ +10 V, 2 V ~ +10 V
ELC-AN04NANN — Analog OUT		2	0			
ELC-AN06AANN — Analog Combo		2	4	±10 V, ±20 mA	2 (12 Bits)	0~20 mA, 0 ~ +10 V
ELC-AN04ANNN — Analog IN		2	4 (V = 12 Bits, I = 11 Bits)	±10 V, ±20 mA	0	
ELC-PT04ANNN — PT100		2	4 (V = 14 Bits, I = 13 Bits)	PT100	0	
ELC-TC04ANNN — Thermocouple		2	4	Thermocouple	0	
ELC-EX08NNSN — Switch Input	24 Vdc	3	8	Switch	0	
ELC-COPBDP — PROFIBUS DP	24 Vdc	4	32	Digital	32	Digital
ELC-CODNET — DeviceNet	24 Vdc	5	32	Digital	32	Digital
ELC-485APTR — RS-485 Easy Connect	N/A	6	0	—	0	—

Figure 34.1-6. ELC Expansion and Specialty Modules — Approximate Dimensions in Inches (mm)

Technical Data and Specifications

Table 34.1-4. ELC Application Data

Description	Specification
Power Supply Voltage	ELC: 24 Vdc (-15% – 20%) (With dc input reverse polarity protection), Expansion Unit: supplied by the ELC
Power Consumption	3 – 6 W
Insulation Resistance	> 5 MΩ at 500 Vdc (Between all inputs/outputs and earth)
Noise Immunity	ESD: 8 kV Air Discharge EFT: Power Line: 2 kV, Digital I/O: 1 kV, Analog and Communication I/O: 250 V Damped-Oscillatory Wave: Power Line: 1 kV, Digital I/O: 1 kV RS: 26 MHz – 1 GHz, 10V/m
Grounding	The diameter of grounding wire cannot be smaller than the wire diameter of terminals L and N (All ELC units should be grounded directly to the ground pole).
Environment	Operation: 0° – 55°C (Temperature), 50 – 95% (Humidity), Pollution degree 2; Storage: -25° – 70°C (Temperature), 5 – 95% (Humidity)
Vibration / Shock Resistance	Standard: IEC1131-2, IEC 68-2-6 (TEST Fc) / IEC1131-2 and IEC 68-2-27 (TEST Ea)
Weight (approx.) (g)	158
Certifications	UL® 508, cUL®, CE

Table 34.1-5. DC Input Point Electrical Specifications

Description	Specification
Input Type	dc (SINK or SOURCE)
Input Current	24 Vdc 5 mA
Active Level	OFF → ON, Above 16 Vdc ON → OFF, Below 14.4 Vdc
Response Time	About 10 ms (An adjustment range of 0 – 10,000 ms could be selected through D1020 and D1021)

Table 34.1-6. Output Point Electrical Specifications

Output Type	Relay – R	Transistor – T	
Current Specification	1.5A/1 point (5A/COM)	0.3A/1 point @ 40°C; When the output of Y0 and Y1 is high-speed pulse, Y0 and Y1 = 30 mA	
Voltage Specification	Below 250 Vac, 30 Vdc	30 Vdc	
Maximum Loading	75 VA (Inductive)	9W/1 point	When the output of Y0 and Y1 is high-speed pulse, Y0 and Y1 = 0.9 W (Y0 = 32 kHz, Y1 = 10 kHz), Y0 can be 50 kHz using D registers.
	90 W (Resistive)		
Response Time	Adjustable 0 – 15 ms, default is 10 ms	OFF → ON 20 μs ON → OFF 30 μs	Y0 and Y1 are specified points for high-speed pulse

Product Selection

Table 34.1-7. ELC Controllers (PB, PC, PA)

Description	Inputs			Outputs			Catalog Number
	ac	dc	Analog	Relay	Transistor	Analog	
14 I/O PB Series	—	8	—	6	—	—	ELC-PB14NNDR
14 I/O PB Series	—	8	—	—	6	—	ELC-PB14NNDT
12 I/O PC Series	8	—	—	4	—	—	ELC-PC12NNAR
12 I/O PC Series	—	8	—	4	—	—	ELC-PC12NNDR
12 I/O PC Series	—	8	—	—	4	—	ELC-PC12NNDT
10 I/O PA Series	—	4	2	2	—	2	ELC-PA10AADR
10 I/O PA Series	—	4	2	—	2	2	ELC-PA10AADT
12 I/O PH Series	—	8	—	—	4	—	ELC-PH12NNDT

Table 34.1-8. Digital I/O Expansion Modules

Description	Inputs		Outputs		Catalog Number
	ac	dc	Relay	Transistor	
6 I/O Expansion (6 Amp Outputs)	—	—	6	—	ELC-EX06NNNI
8 I/O Expansion — ac IN	8	—	—	—	ELC-EX08NNAN
8 I/O Expansion — ac IN	—	8	—	—	ELC-EX08NNDN
8 I/O Expansion — Relay OUT	—	—	8	—	ELC-EX08NNNR
8 I/O Expansion — Transistor OUT	—	—	—	8	ELC-EX08NNNT
8 I/O Expansion — IN/OUT Combo	—	4	4	—	ELC-EX08NNDR
8 I/O Expansion — IN/OUT Combo	—	4	—	4	ELC-EX08NNDT
16 I/O Expansion — IN/OUT Combo	—	8	8	—	ELC-EX16NNDR
16 I/O Expansion — IN/OUT Combo	—	8	—	8	ELC-EX16NNDT
8 I/O Expansion — Switch Input	—	8	—	—	ELC-EX08NNSN

Table 34.1-9. Analog I/O Modules

Description	Analog In	Analog Out	Catalog Number
4 I/O Analog In	4	—	ELC-AN04ANNN
2 I/O Analog Out	—	2	ELC-AN02NANN
4 I/O Analog Out	—	4	ELC-AN04NANN
6 I/O Analog In/Out	4	2	ELC-AN06AANN
4 I/O Thermocouple J, K, R, S, T, PT100	4	—	ELC-TC04ANNN
4 I/O Platinum	4	—	ELC-PT04ANNN

Table 34.1-10. Accessory Modules

Description
PROFIBUS DP Module
DeviceNet Module
RS-485 Easy Connect Adapter, DB9, RJ-12, 2-Pin Connections to RS-485

ELC Graphic Panels

ELC Graphic Panels

Product Description

ELC Graphic Panels are simple to program and easily connect to ELC products. ELC graphic panels make modifying an application quick and easy. ELC graphic panels also connect to Cutler-Hammer® MVX drives, IQ Modbus meters and many other devices. With over 30 objects that can be placed anywhere on the display, these panels also communicate to other major controllers. These graphic panels have two serial ports which can be used simultaneously to communicate. Transfer applications to or from these graphic panels using the handy transfer module. Ten programmable functions keys provide easy to change pages, input numeric values, enter alpha-numeric passwords, set, reset and more. Create alarms, password protect, import bitmaps, and use many different fonts.

Protocols Supported

- Eaton D50/D32LT, D320.
- Eaton ELC.
- Eaton MVX ASCII.
- Eaton MVX RTU.
- Modbus ASCII.
- Modbus RTU.
- AB DF1.
- Mitsubishi FX Series.
- Mitsubishi FX2N Series.
- Koyo K-Sequence.
- LG 200S.
- OMRON C-Series.
- Siemens® 57-200 Series.
- ASCII Slave Mode.
- And more...



ELC-GP04



ELC-GP02

Table 34.1-11. ELC Graphic Panel Features

Item	ELC-GP02	ELC-GP04
Display Screen		
Screen	STN-LCD	
Color	Monochromatic	
Back-light	The Back-light Automatic Turn Off Time is 1 – 99 Minutes (0 = Do Not to Turn Off) (Back-light Life is 50 Thousand Hours at 25°C)	
Resolution	160 x 32 Pixels	128 x 64 Pixels
Display Range	72 mm (W) x 22 mm (H)	67 mm (W) x 32 mm (H); 3.00" (Diagonal Preferred)
Contrast Adjustment	15-Step Contrast Adjustment	10-Step Contrast Adjustment
Language Font	ASCII: Characters (Including European Fonts) Taiwan: (BIG 5 Code) Traditional Chinese Character Font China: (GB2324-80 Code) Simplified Chinese Character Font	
Font Size (ASCII)	5 x 8, 8 x 8, 8 x 12, 8 x 16	
ALARM Indication LED	1. Power on Indication (Flash Three Times) 2. Flash for Communication Error or Other Alarm 3. Special Indication by User Programming	
RS-232 LED (Yellow)	Flashes when Communicating	
RS-485 LED (Green)	Flashes when Communicating	
Program Memory		
Program Memory	256 KB Flash Memory	
External Interface		
Serial Communication Port RS-232 (COM1) 9 PIN D-SUB Male	Data Length: 7 or 8 Bits Stop Bits: 1 or 2 Bits Parity: None/Odd/Even Baud Rate: 4800 bps – 115200 bps	
Extension Communication Port RS-485 (COM2) 5-Pin Removal Terminal (RS-485 or RS-422)	Data Length: 7 or 8 bits Stop Bits: 1 or 2 bits Parity: None/Odd/Even Baud Rate: 4800 bps – 115200 bps	
Extension Slot	The Slot for Program Copy Card	
Power	24 Vdc Input	

Technical Data and Specifications

Table 34.1-12. ELC-GP04 Electrical Specifications

Description	Specification
Communication Interface	COM1: RS232; COM2: RS485/RS422
Waterproof Class of Front Panel	IP65/NEMA® Type 4
Temperature for Hardware	0 – 50°C, Relative Humidity 20 – 90% RH (Non-condensing)
Storage Temperature for Hardware	-20 – 60°C
Vibration	0.5 mm Displacement, 10 – 55 Hz, X, Y, Z Three Directions and Two Hours for each Direction
Impact	10G, 11 ms, from X, Y, Z Three Directions and Three Times for each Direction
Radiated Emission	CISPR22, Class A
Electrostatic Discharge Immunity	EN61000-4-2/1995
Radiated Immunity	EN61000-4-3/1995
Electrical Fast Transient	EN61000-4-4/1995
Weight/Dimension	0.24 kg/147 x 97 x 35.5 mm (Width x Height x Depth)
Cooling Method	Natural Air Cooling
Certifications	UL 508, Class 1 Division 2 Groups ABCD, cUL, CE

Dimensions

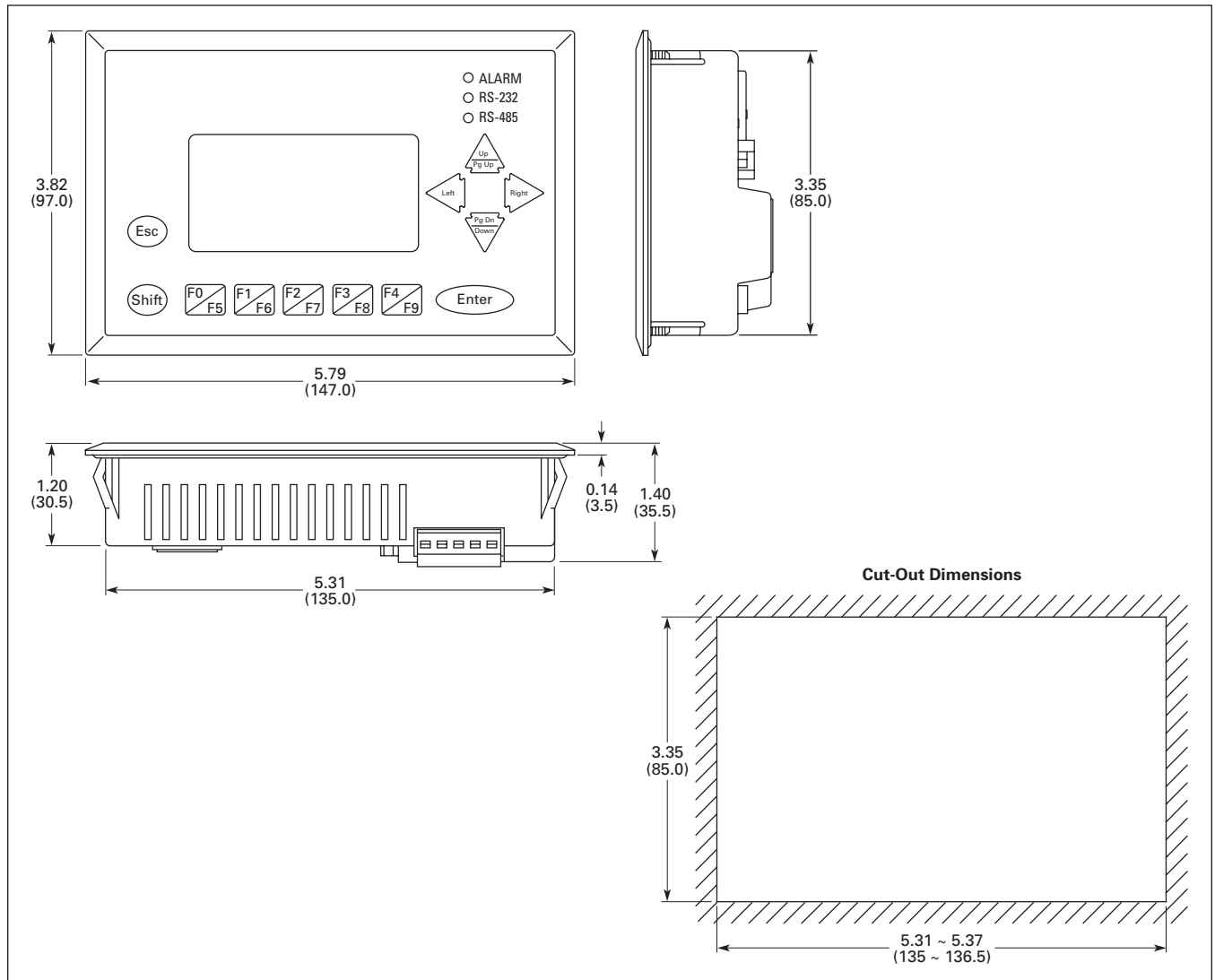

Figure 34.1-7. Model ECL-GP02 and ECL-GP04 Graphic Panels — Approximate Dimensions in Inches (mm)

ELC Graphic Panels

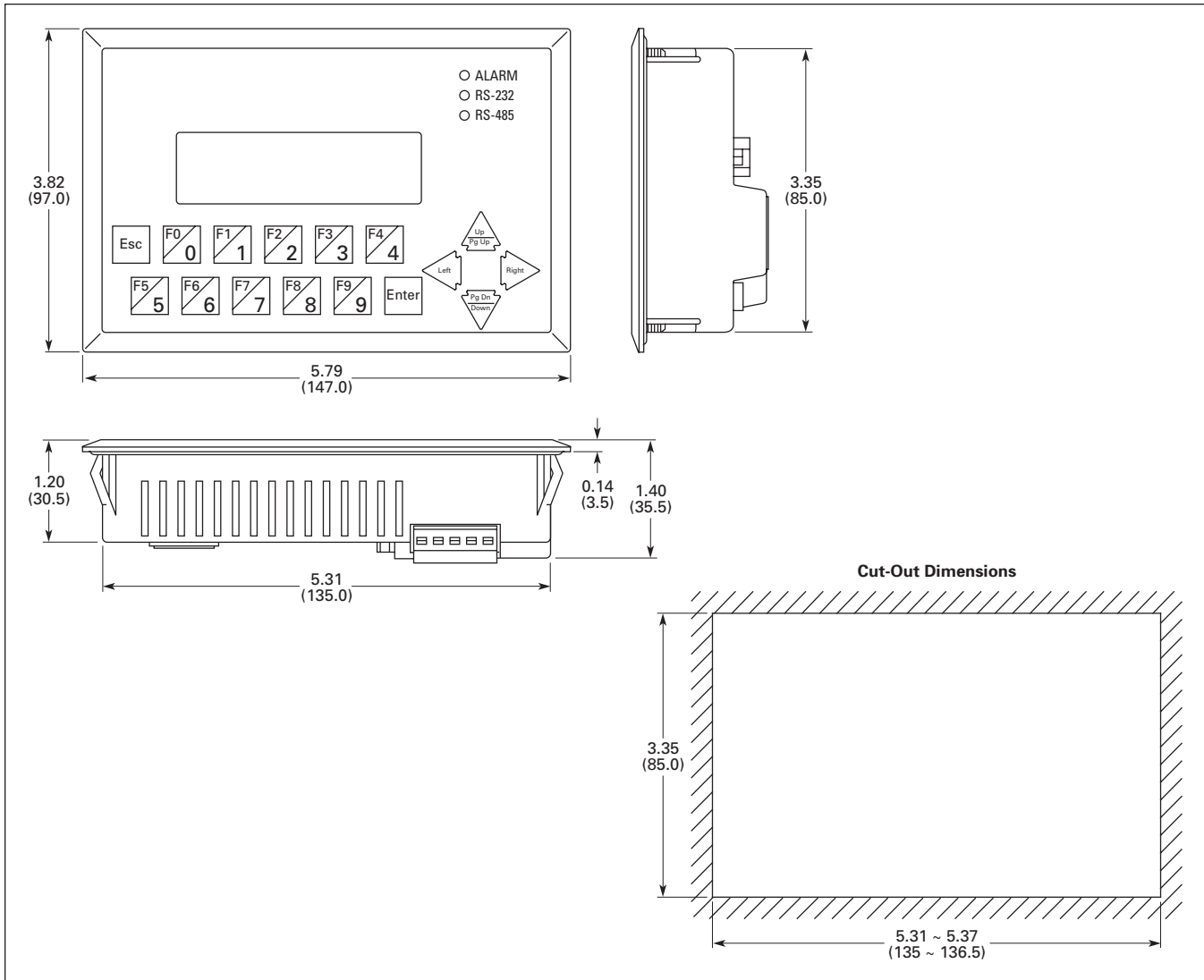

Figure 34.1-8. ECL-GP02 — Approximate Dimensions in Inches (mm)

Product Selection

Table 34.1-13. Graphics Panels

Description	Catalog Number
160 x 32 pixels, 10 Function Keys, Monochrome	ELC-GP02
128 x 64 pixels, 10 Function Keys, Monochrome	ELC-GP04

ELC Software

ELCSoft Programming Software

ELCSoft Programming Software configures all ELC controllers. With ELCSoft, applications can be created, edited, monitored, forced, etc. Move programs from one controller to a different one with ease.

Requirements:

- **Operating Systems** — Windows® 98, Windows ME, Windows 2000, Windows XP.
- **Hard Drive** — At least 100M bytes.
- **RAM** — At least 256M bytes.

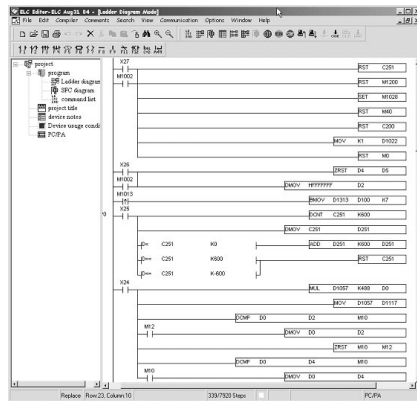

ELCSoft Ladder Diagram Mode

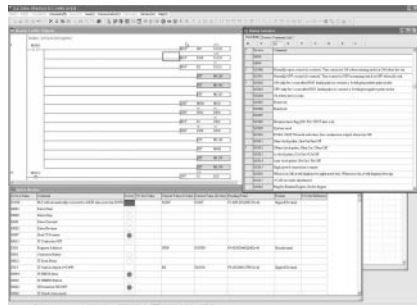

ELCSoft Editor

ELCSoftGP Programming Software

ELCSoftGP Programming Software configures all ELC graphic panels. With ELCSoftGP, applications can be created, edited, downloaded, uploaded, etc. Move programs from one controller to a different one with ease.

Requirements:

- **Operating Systems** — Windows 98, Windows ME, Windows 2000, Windows XP.
- **Hard Drive** — At least 100M bytes.
- **RAM** — At least 256M bytes.

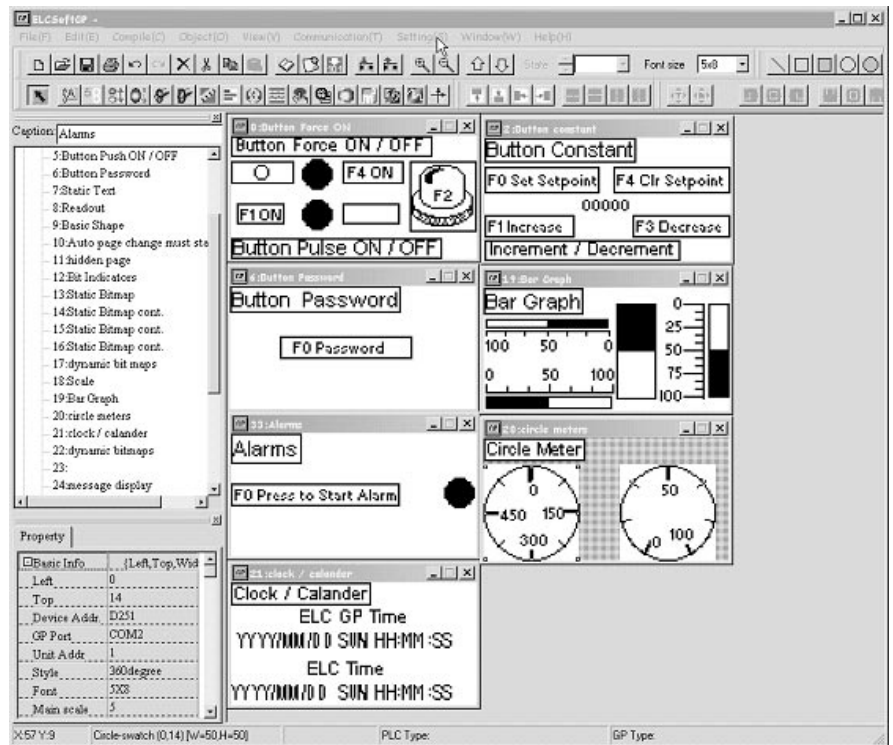

ELCSoftGP Editing Environment

Product Selection

Table 34.1-14. Software

Description	Catalog Number
Programming Software for ELC Controllers	ELCSOFT
Programming Software for GP Units	ELCSOFTGP

ELC Accessories

ELC Accessories

ELC-GPXFERMOD

Transfer programs to or from ELC-GPxx units. These devices can be write protected to maintain program integrity.

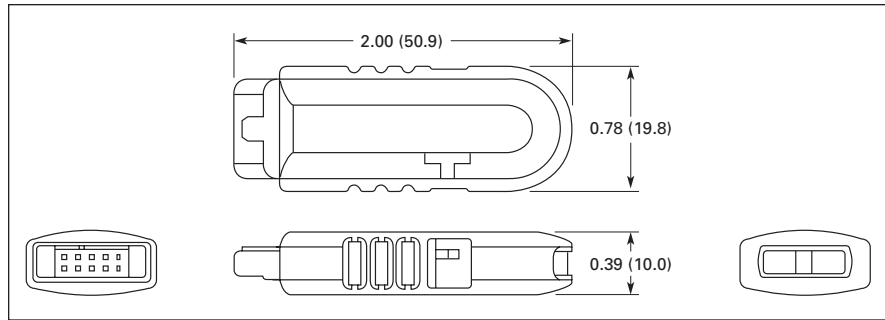

Figure 34.1-9. ELC — GPXFERMOD — Approximate Dimensions in Inches (mm)

ELC-HHP

ELC-HHP is an easy-to-use, hand-held programming tool for ELC controllers when a PC is not available. With ELC-HHP, applications can be programmed directly with the attached keypad. Or uploaded from an ELC, saved, and transferred to a different ELC. Or downloaded from a PC and transferred to other ELCs. No need for outlets when using the ELC-HHP since it draws its power from either the ELC or the PC through the attached cable. Monitor applications when a PC is not available.

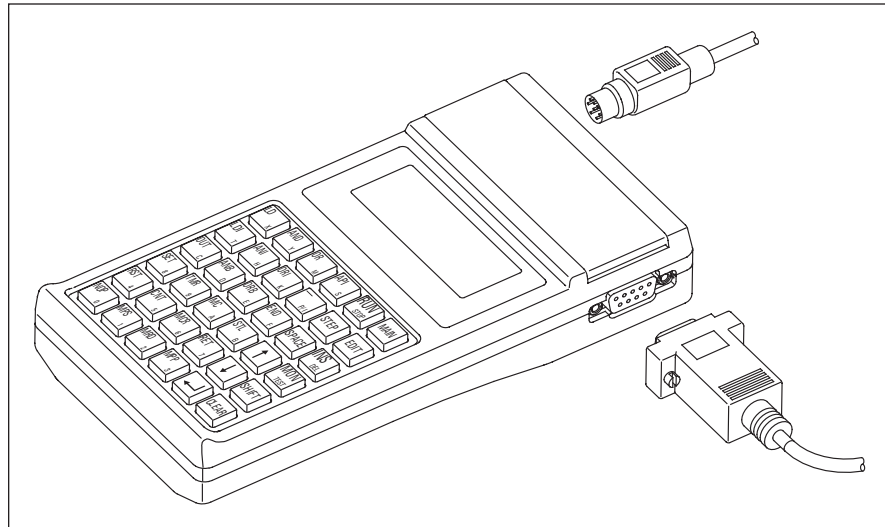

Figure 34.1-10. ELC-HHP with Cables for ELC and PC Connections

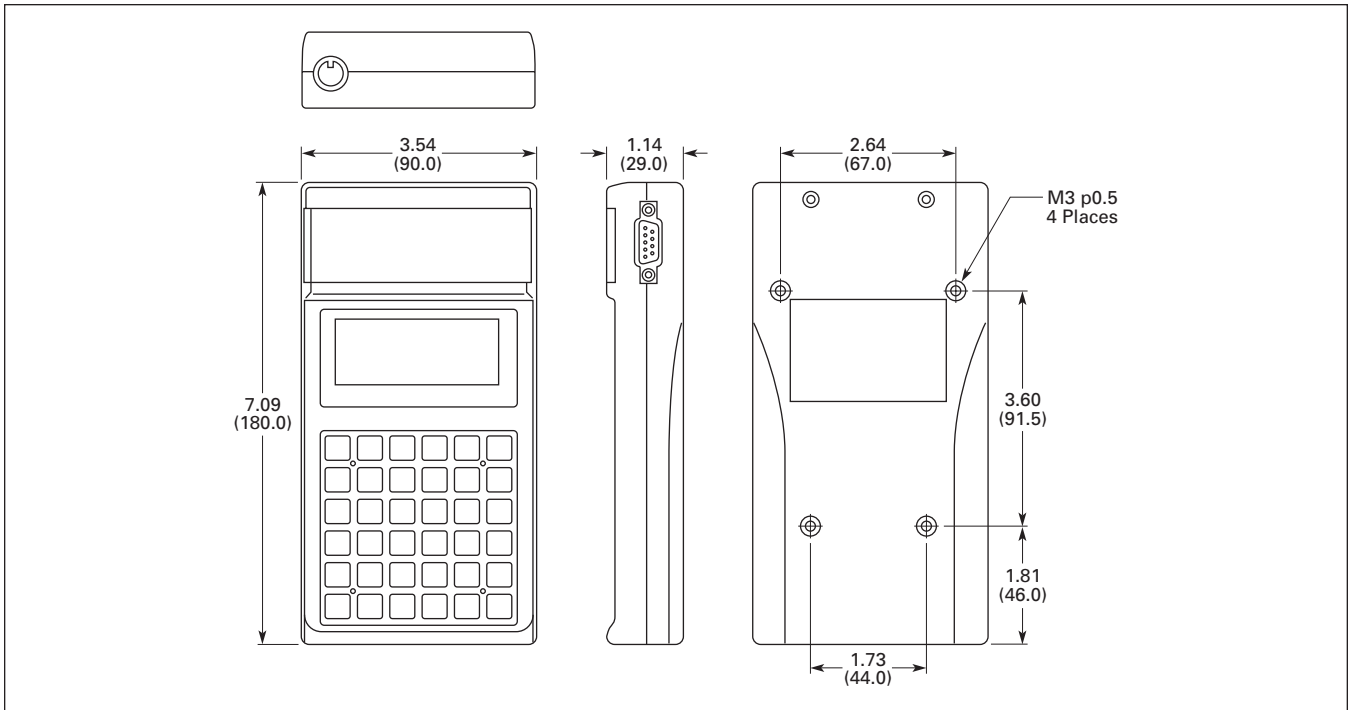

Figure 34.1-11. ELC — HHP Hand-Held Programmer — Approximate Dimensions in Inches (mm)

ELC Power Supplies

All ELC modules operate from 24 Vdc.
These power supplies provide a convenient way to provide robust dc voltage.

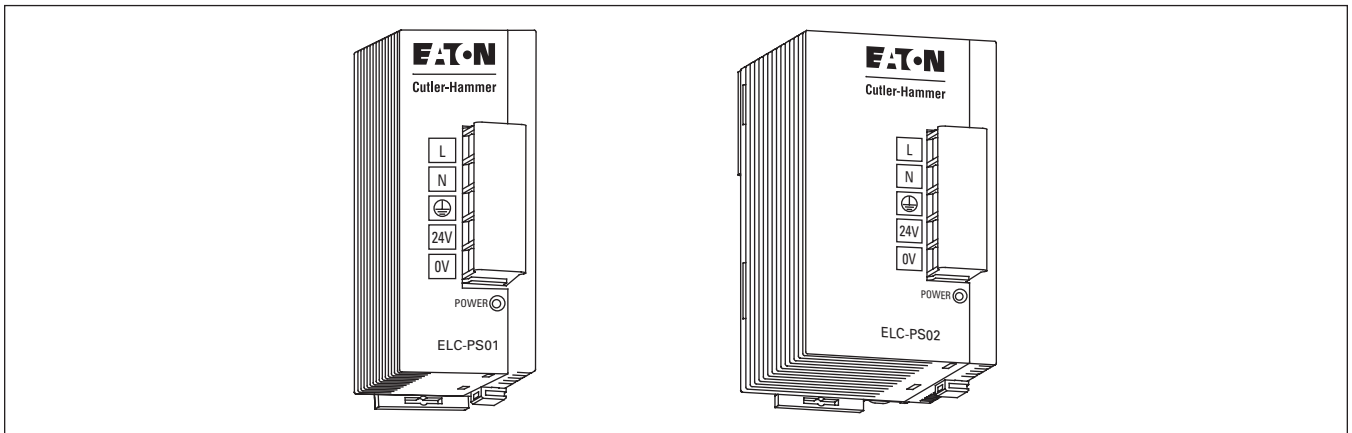

Figure 34.1-12. ELC Power Supplies

Table 34.1-15. ELC Power Supply Specifications

Item	ELC-PS01	ELC-PS02
Dimensions W x H x D in Inches (mm)	1.44 x 3.54 x 2.36 (36.5 x 90 x 60)	2.17 x 3.54 x 2.36 (55 x 90 x 60)
Input Power	100 – 240 Vac 50/60 Hz	
Output Volts	24 Vdc	
Output Current (A)	1A	2A
Output Watts	24 W	48 W

ELC Accessories

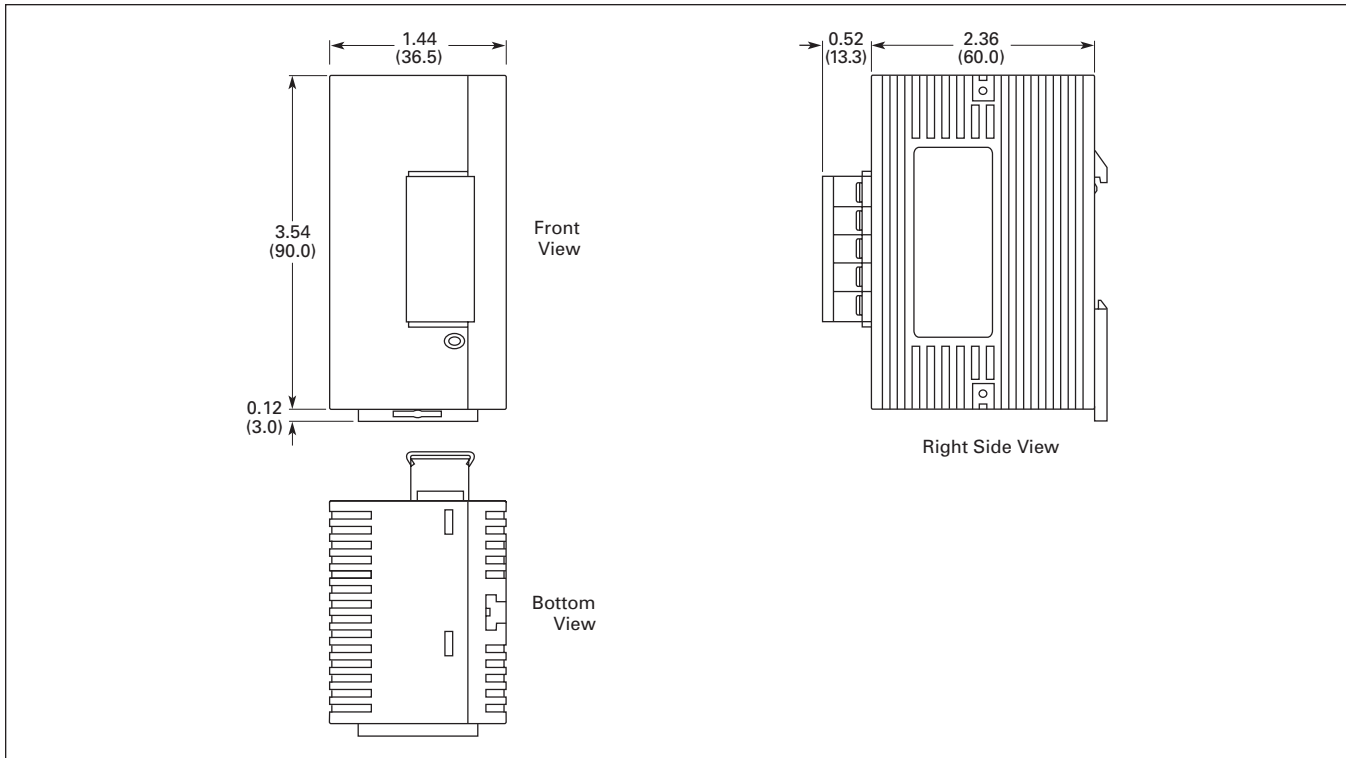

Figure 34.1-13. ELC-PS01 Power Supply — Approximate Dimensions in Inches (mm)

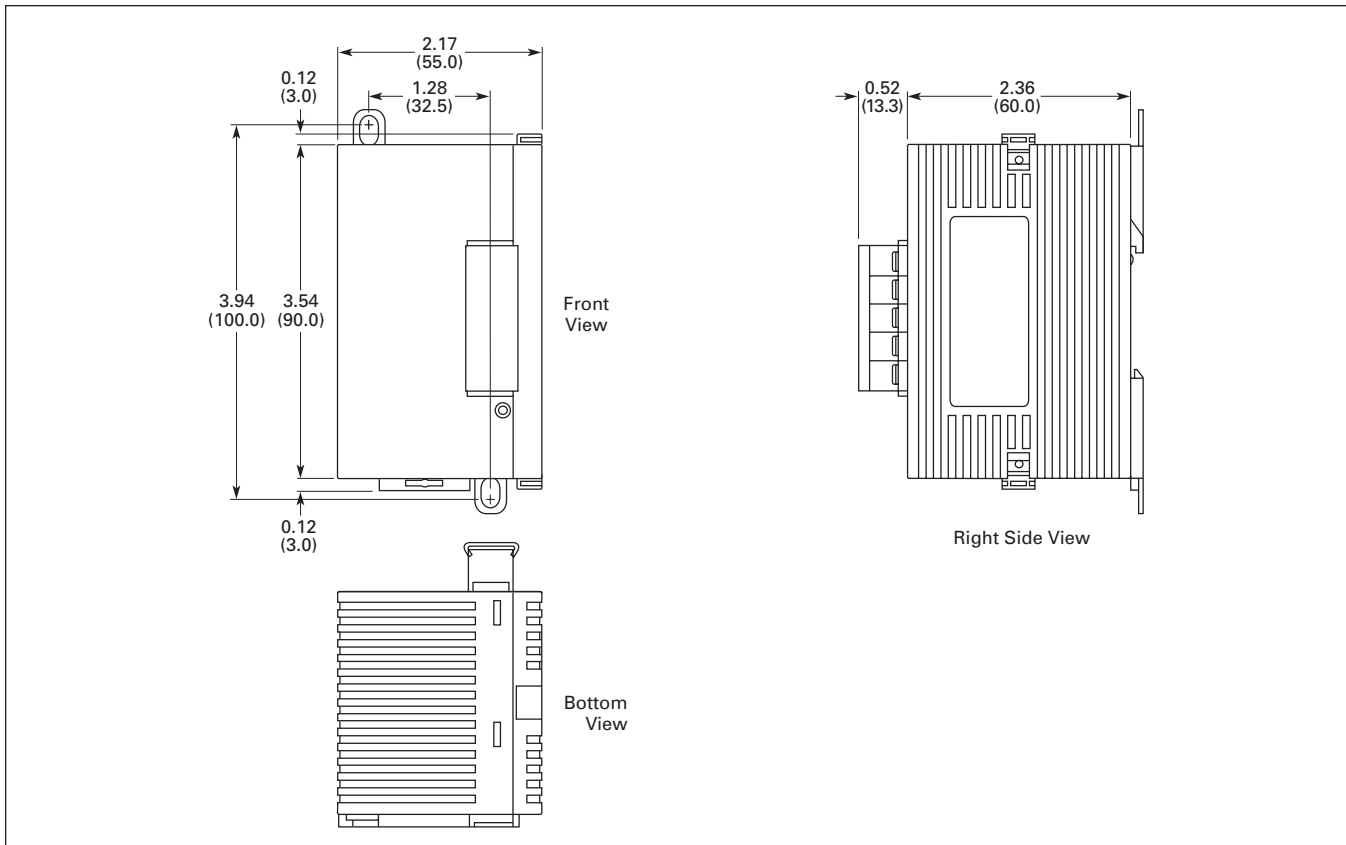

Figure 34.1-14. ELC-PS02 Power Supply — Approximate Dimensions in Inches (mm)

ELC-CBPCELC3

Use this cable to download, upload, monitor ELC controllers. Or use this same cable to connect any ELC-GPxx to an ELC controller. This cable is 3 meters long.

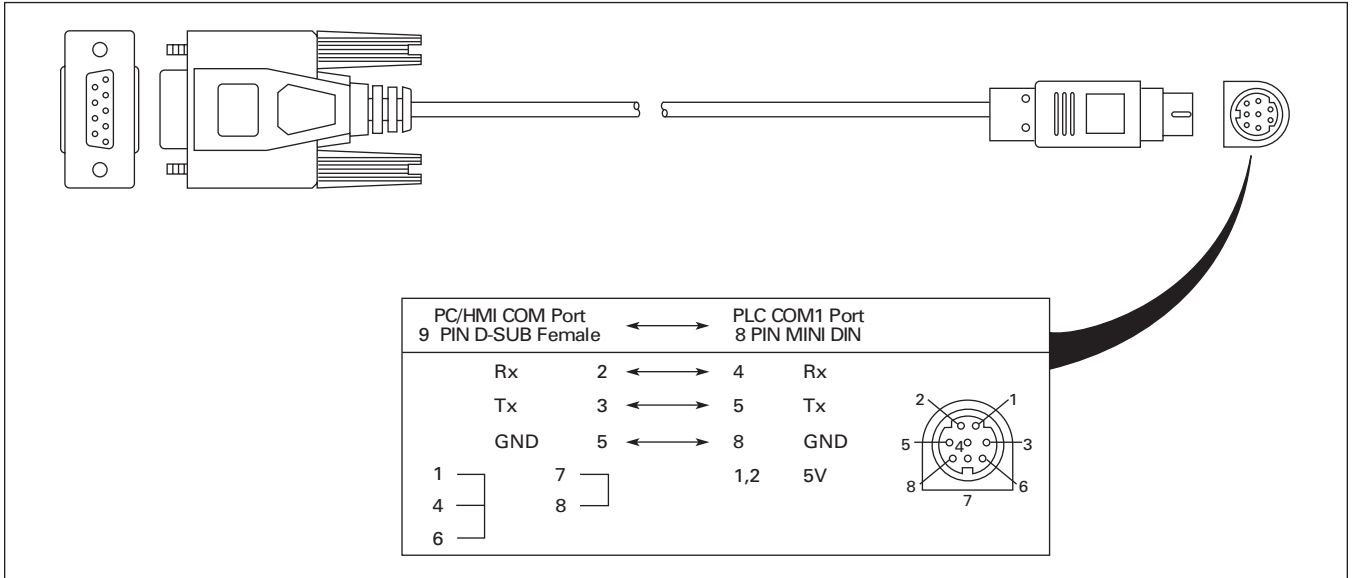

Figure 34.1-15. ELC-CBPCELC3 Cable

ELC-CBP CGP3

Use this cable to download or upload applications between a PC and the ELC-GPxx graphic panels. This cable can also be used to transfer a program from an ELC-GPxx to another ELC-GPxx. This cable is 3 meters long.

The Pin definition of 9 PIN D-SUB RS-232:

ELC-GP04 COM Port RS-232 9 PIN D-SUB Male	
3	Tx
2	Rx
5	GND

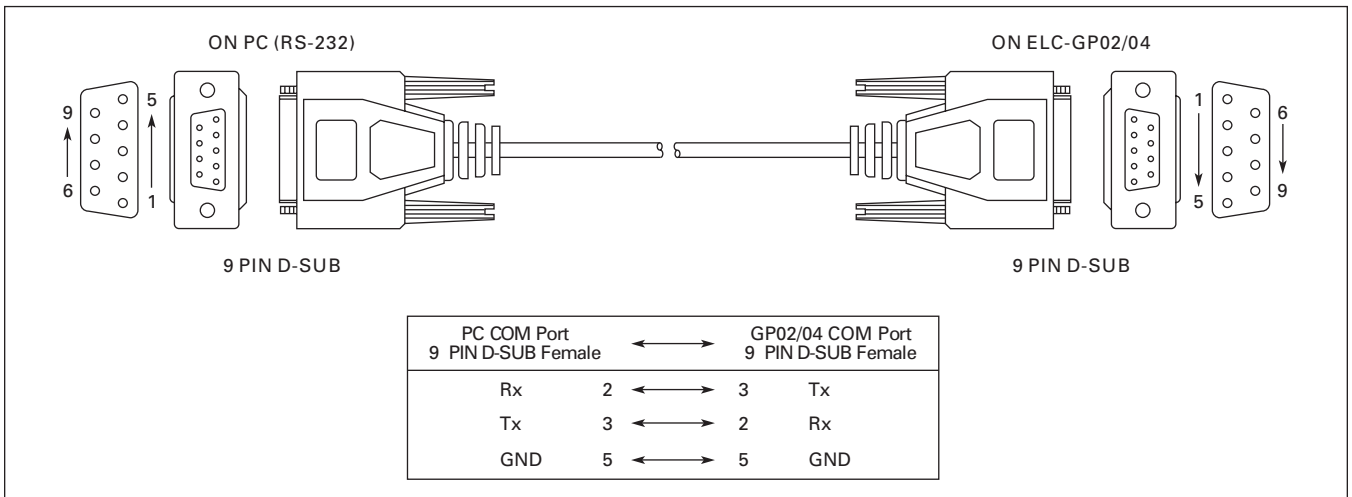

Figure 34.1-16. PC or GP02/04

ELC Accessories

Table 34.1-16. ELC Accessories

Description	Catalog Number
24 Watt, 1 Amp Power Supply	ELC-PS01
48 Watt, 2 Amp Power Supply	ELC-PS02
Hand-Held Programmer (Includes ELC-CBHHELC15)	ELC-HHP
Cable to Connect a PC or a GP Unit to ELC, 3 Meters (DB9 Pin Female to 8 Pin DIN)	ELC-CBPCELC3
Cable to Connect a PC to a GP Unit, 3 Meters (DB9 Pin Female to DB9 Pin Female)	ELC-CBP CGP3
Program Transfer Module for GP Units	ELC-GPXFERMOD
Program Transfer Module for ELC Controllers	ELC-ACPGMXFR
Plate Mount for Specialty Modules, Qty. 10	ELC-ACCOVER
ELC Starter Kit (Includes ELC-PA10AADT, ELC-PS01, ELC-GP04, ELC-CBPCELC3, ELC-CBP CGP3, ELCSOFT, ELCSOFT GP)	ELCSTARTKIT1

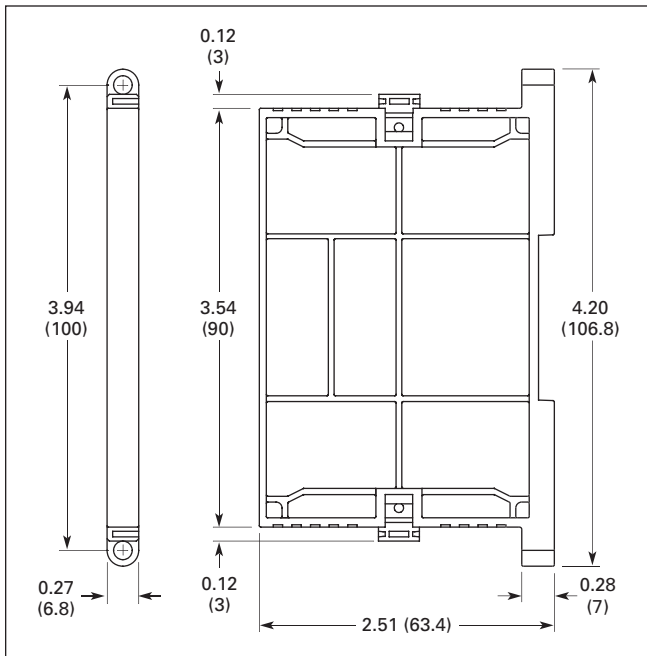

Figure 34.1-17. Plate Mount for Specialty Modules

Product Family Overview

EZ Intelligent Relays Product Family Overview

**EZ Intelligent Relays Product Family**

The EZ intelligent relays bring timers, relays, counters, special functions, inputs and outputs into one compact device that is easily configured. The EZ family of products provides exceptional levels of flexibility together with substantial savings in commissioning time and effort.

The EZ intelligent relays are available in more than 32 different styles that support from 12 I/O up to 320 I/O points providing the ideal solution for lighting, energy management, industrial control, watering, pump control, HVAC and home automation.

Once EZ products are installed, changes are easily accomplished through front panel programming, eliminating the need to change wiring and wiring diagrams increasing the savings realized.

Other terms often used for intelligent relay are relay replacer, control relay and smart relay.

Application Description

Generally where multiple relays, timers and pushbuttons are used there is an opportunity to evaluate switching to the EZ Intelligent Relays. Applications span residential, commercial and industrial installations. Typical applications are:

- Car washes.
- Automatic door control.
- Commercial lighting.
- Residential lighting.
- Exterior lighting.
- Pump control, 12 Vdc automotive control.
- Greenhouse control.
- Crane control.
- Machinery.
- Paper/pulp.
- Elevator control.
- Livestock feed/gate control.
- Irrigation control.
- Cart chargers.
- Heating and air conditioning.

EZ 500/700/800/EZD Intelligent Relays

EZ 500/700/800/EZD Intelligent Relays

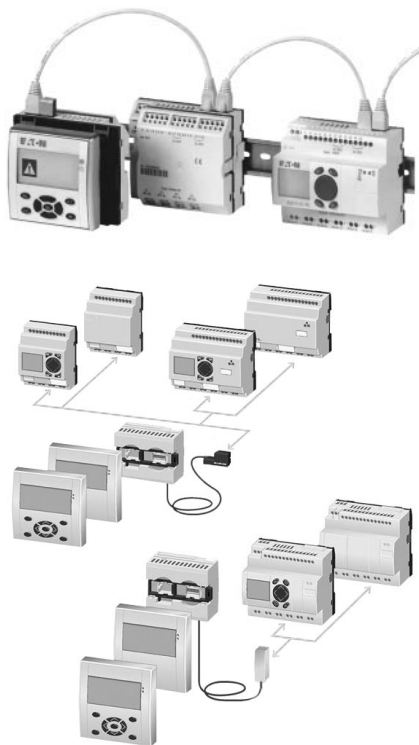

EZ 500/700/800/EZD Intelligent Relays

EZD Series — for controlling large-scale applications with up to 320 input/output signals using powerful visualization functions. The EZD display can be linked to the EZ500/700/800 models to provide an enhanced operator interface. Panel mounted.

The **EZ-NET** integrated network called provides easy and inexpensive linking of up to eight EZ800/EZD devices over a distance of up to 1000 meters. The EZ and EZD devices can run their own program or be used as a distributed input/output module.

Catalog Number Selection

Table 34.2-1. EZ500/700/800 Module Definition Catalog Numbering System

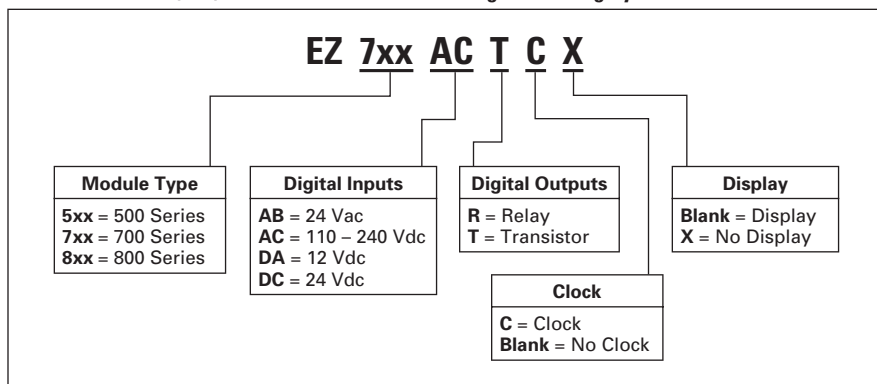

Product Selection

EZ500 Intelligent Relays



EZ500 with Display



EZ500 without Display

Table 34.2-2. EZ500 Intelligent Relays

Description	Inputs					Outputs		Catalog Number
	24 Vac	110 - 240 Vac	12 Vdc	24 Vdc	ALG	RY	TRN	
12 I/O, Clock, Display	8	—	—	—	2	4	—	EZ512-AB-RC
12 I/O, Clock, No Display	8	—	—	—	2	4	—	EZ512-AB-RCX
12 I/O, No Clock, Display	—	8	—	—	—	4	—	EZ512-AC-R
12 I/O, Clock, Display	—	8	—	—	—	4	—	EZ512-AC-RC
12 I/O, Clock, No Display	—	8	—	—	—	4	—	EZ512-AC-RCX
12 I/O, Clock, Display	—	—	8	—	2	4	—	EZ512-DA-RC
12 I/O, Clock, No Display	—	—	8	—	2	4	—	EZ512-DA-RCX
12 I/O, No Clock, Display	—	—	—	8	2	4	—	EZ512-DC-R
12 I/O, Clock, Display	—	—	—	8	2	4	—	EZ512-DC-RC
12 I/O, Clock, No Display	—	—	—	8	2	4	—	EZ512-DC-RCX
12 I/O, Clock, Display	—	—	—	8	2	—	4	EZ512-DC-TC
12 I/O, Clock, No Display	—	—	—	8	2	—	4	EZ512-DC-TCX

Note: Analog inputs optional.

Product Description

Four families make up the EZ Intelligent Relay product line.

EZ500 Series — for controlling small applications with up to 12 input/output signals. Models are available with and without displays. DIN rail mounted.

EZ700 Series — for controlling medium-sized applications with up to 40 input/output signals. DIN rail mounted.

EZ800 Series — for controlling large-scale applications with up to 320 input/output signals. Models are available with and without displays. DIN rail mounted.

EZ700 Intelligent Relays

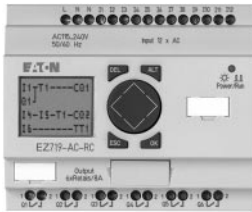

EZ700 with Display



EZ700 without Display

Table 34.2-3. EZ700 Intelligent Relays

Description	Inputs					Outputs		Catalog Number
	24 Vac	110 – 240 Vac	12 Vdc	24 Vdc	Analog	Relay	Transistor	
18 I/O, Clock, Display	12	—	—	—	4	6	—	EZ719-AB-RC EZ719-AB-RCX
18 I/O, Clock, No Display	12	—	—	—	4	6	—	
18 I/O, Clock, Display	—	12	—	—	—	6	—	EZ719-AC-RC EZ719-AC-RCX
18 I/O, Clock, No Display	—	12	—	—	—	6	—	
18 I/O, Clock, Display	—	—	12	—	4	6	—	EZ719-DA-RC EZ719-DA-RCX
18 I/O, Clock, No Display	—	—	12	—	4	6	—	
18 I/O, Clock, Display	—	—	—	12	4	6	—	EZ719-DC-RC EZ719-DC-RCX
18 I/O, Clock, No Display	—	—	—	12	4	6	—	
20 I/O, Clock, Display	—	—	—	12	4	—	8	EZ721-DC-TC EZ721-DC-TCX
20 I/O, Clock, No Display	—	—	—	12	4	—	8	

Note: Analog inputs optional.

EZ800 Intelligent Relays



EZ800 with Display



EZ800 without Display

Table 34.2-4. EZ800 Intelligent Relays

Description	Inputs			Outputs			Catalog Number
	110 – 240 Vac	24 Vdc	Analog	Relay	Transistor	Analog	
18 I/O, Clock, Display	12	—	—	6	—	—	EZ819-AC-RC EZ819-AC-RCX
18 I/O, Clock, No Display	12	—	—	6	—	—	
18 I/O, Clock, Display	—	12	4	6	—	—	EZ819-DC-RC EZ819-DC-RCX
18 I/O, Clock, No Display	—	12	4	6	—	—	
19 I/O, Clock, Display	—	12	4	6	—	1	EZ820-DC-RC EZ820-DC-RCX
19 I/O, Clock, No Display	—	12	4	6	—	1	
20 I/O, Clock, Display	—	12	4	—	8	—	EZ821-DC-TC EZ821-DC-TCX
20 I/O, Clock, No Display	—	12	4	—	8	—	
21 I/O, Clock, Display	—	12	4	—	8	1	EZ822-DC-TC EZ822-DC-TCX
21 I/O, Clock, No Display	—	12	4	—	8	1	

Note: Analog inputs optional, analog outputs optional.

EZ 500/700/800/EZD Intelligent Relays

EZD Displays and Controllers



EZD-80



EZD-CP8



EZD I/O



EZD Assembly

Table 34.2-5. EZD Displays (EZD-80) and EZD Controllers (EZD-CP8)

Description	Catalog Number
EZD, No Buttons	EZD-80
EZD, Buttons	EZD-80-B
EZD CPU with 24 Vdc, Power Supply, Clock	EZD-CP8-ME
EZD CPU with 24 Vdc, Power Supply, Clock, EZ-Net	EZD-CP8-NT
EZD CPU with 100 – 240 Vac, Power Supply, Clock	EZD-AC-CP8-ME
EZD CPU with 100 – 240 Vac, Power Supply, Clock, EZ-Net	EZD-AC-CP8-NT

Table 34.2-6. EZD I/O Modules

Description	Inputs			Outputs			Catalog Number
	110 – 240 Vac	24 Vdc	Analog	Relay	Transistor	Analog	
16 I/O	12	—	—	4	—	—	EZD-AC-R16
16 I/O	—	12	4	4	—	—	EZD-R16
17 I/O	—	12	4	4	—	1	EZD-RA17
16 I/O	—	12	4	—	4	—	EZD-T16
17 I/O	—	12	4	—	4	1	EZD-TA17

Note: Analog inputs optional.

EZD Display to EZ Communication Modules



EZD-CP4-800 Attached to EZ-80 Display and EZ800 Unit

Table 34.2-7. EZD Display to EZ Communication Modules (EZD-CP4)

Description	Catalog Number
EZD Display to EZ500/700 Communication Module with EZ500/700 Communication Cable (EZD-CP4-500-CAB5)	EZD-CP4-500
EZD Display to EZ800 Communication Module with EZ800 Communication Cable (EZD-CP4-800-CAB5)	EZD-CP4-800

Technical Data and Specifications

Table 34.2-8. EZ500 Series

Type	EZ512-AB...	EZ512-AC...	EZ512-DA...	EZ512-DC-R...	EZ512-DC-TC.
Supply Voltage	24 Vac	100 – 240 Vac	12 Vdc	24 Vdc	24 Vdc
Heat Dissipation	5 VA	5 VA	2 W	2 W	2 W
Continuous Current Outputs (1)	8 A	8 A	8 A	8 A	0.5 A
Short-circuit Proof with Power Factor 1	Line Protection B16, 600 A				—
Short-circuit Proof with Power Factor 0.7...0.7	Line Protection B16, 900 A				—
Mounting	On Top-hat Rail to DIN 50022, 35 mm or Screw Mounting with EZB4-101-GF1 Fixing Brackets				

Table 34.2-9. EZ700 Series

Type	EZ719-AB...	EZ719-AC...	EZ719-DA...	EZ719-DC-RC.	EZ721-DC-TC.
Supply Voltage	24 Vac	100 – 240 Vac	12 Vdc	24 Vdc	24 Vdc
Heat Dissipation	7 VA	10 VA	3.5 W	3.5 W	3.5 W
Continuous Current Outputs (1)	8 A	8 A	8 A	8 A	0.5 A
Short-circuit Proof with Power Factor 1	Line Protection B16, 600 A				—
Short-circuit Proof with Power Factor 0.7...0.7	Line Protection B16, 900 A				—
Mounting	On Top-hat Rail to DIN 50022, 35 mm or Screw Mounting with EZB4-101-GF1 Fixing Brackets				

Table 34.2-10. EZ800 Series

Type	EZ819-AC...	EZ819-DC-RC.	EZ820-DC-RC.	EZ821-DC-TC.	EZ822-DC-TC.
Supply Voltage	100 – 240 Vac	24 Vdc	24 Vdc	24 Vdc	24 Vdc
Heat Dissipation	10 VA	3.4 W	3.4 W	3.4 W	3.4 W
Continuous Current Outputs (1)	8 A	8 A	8 A	8 A	0.5 A
Short-circuit Proof with Power Factor 1	Line Protection B16, 600 A				—
Short-circuit Proof with Power Factor 0.7...0.7	Line Protection B16, 900 A				—
Mounting	On Top-hat Rail to DIN 50022, 35 mm or Screw Mounting with EZB4-101-GF1 Fixing Brackets				

Table 34.2-11. EZD CP4 and CP8 Modules

Type	EZD-80...	EZD-CP4...	EZD-CP8...	EZD-AC-CP8...
Supply Voltage	Supply from -CP	24 Vdc	24 Vdc	100 – 240 Vac
Heat Dissipation	3 W	1.5 W	3 W	8 VA
Mounting	Front Mounting in 2 x 22.5 mm Standard Drill Holes	Snap Fitted to EZD-80	Snap Fitted to EZD-80 or on Top-hat Rail to DIN 50022, 35 mm or Screw Mounting with EZB4-101-GF1 Fixing Brackets	

Table 34.2-12. EZ500, EZ700, EZ800, EZD-80, EZD-CP4, EZD-CP8 Modules

Type	EZD-80...	EZ500/700/800, EZD-CP4/CP8
Connection Cables	—	0.2 – 4.0 mm ² (AWG 22-12), solid 0.2 – 2.5 mm ² (AWG 22-12), flexible
Degree of Protections	IP65	IP 20
RFI Suppression	EN 55011, EN 55022 Class B, IEC 61000-6-1,2,3,4	EN 55011, EN 55022 Class B, IEC 61000-6-1,2,3,4
Ambient Operating Temperature	Clearly Legible at -5 to 50°C	-25 to 55°C
Transport and Storage Temperature	-40 to 70°C	-40 to 70°C
Certification, Standards	EN 50178, IEC/EN 60947, UL, CSA®	EN 50178, IEC/EN 60947, UL, CSA

Dimensions

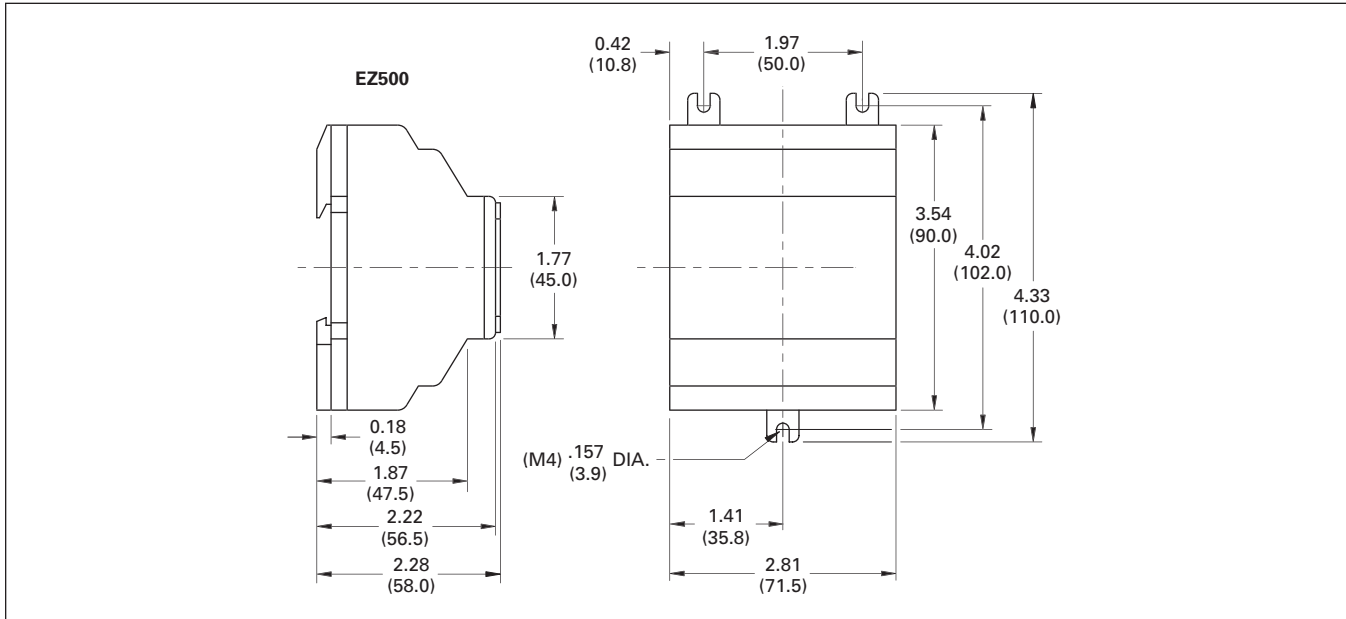

Figure 34.2-1. EZ500 Series Dimensions in Inches (mm), Drawing Number MD05013001E

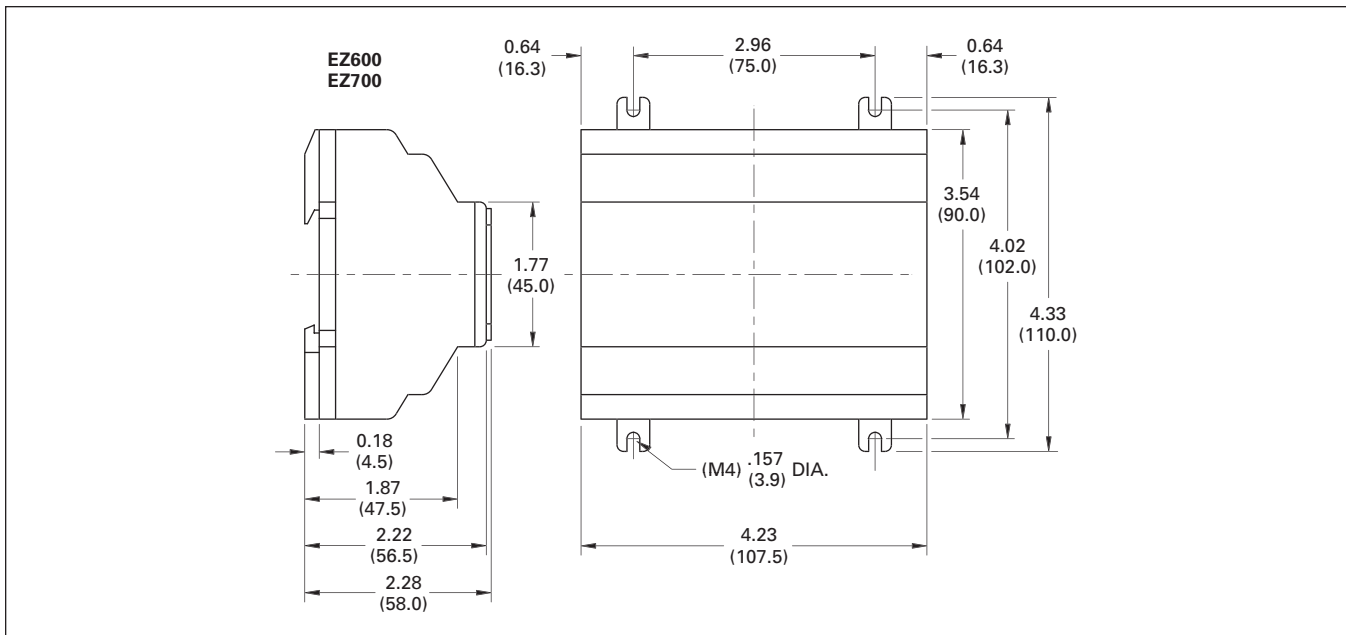

Figure 34.2-2. EZ600 and EZ700 Series Dimensions in Inches (mm), Drawing Number MD05013002E

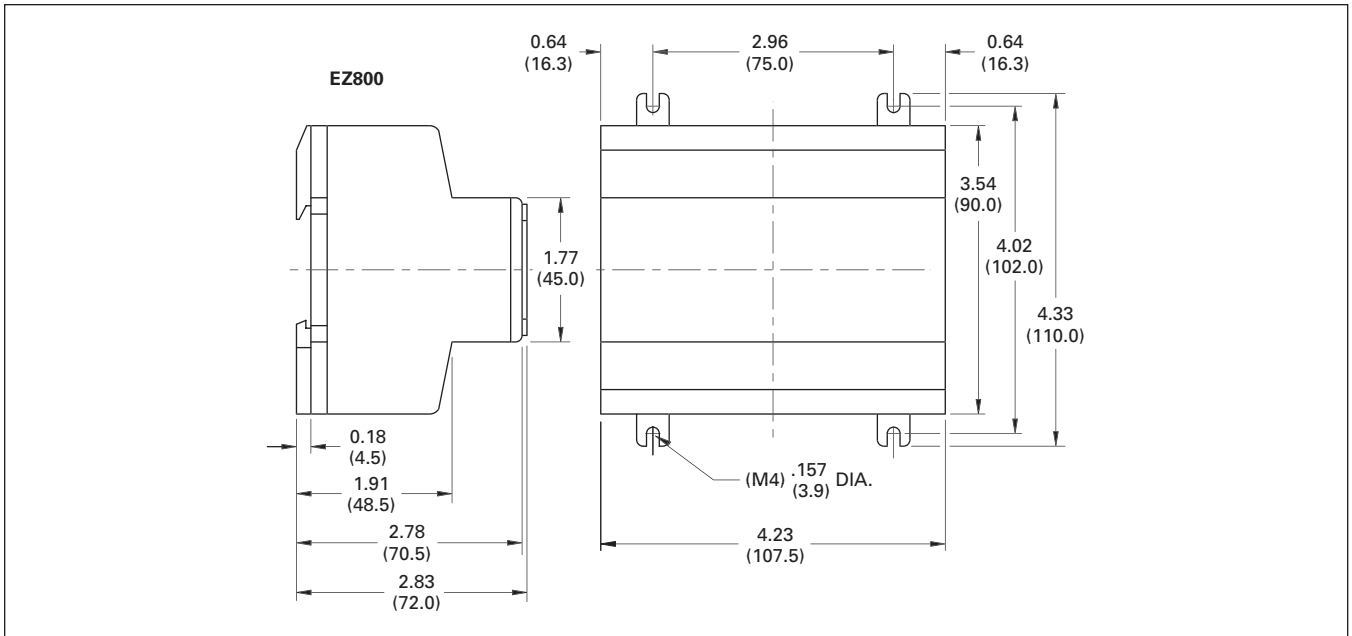

Figure 34.2-3. EZ800 Series Dimensions in Inches (mm), Drawing Number MD05013003E

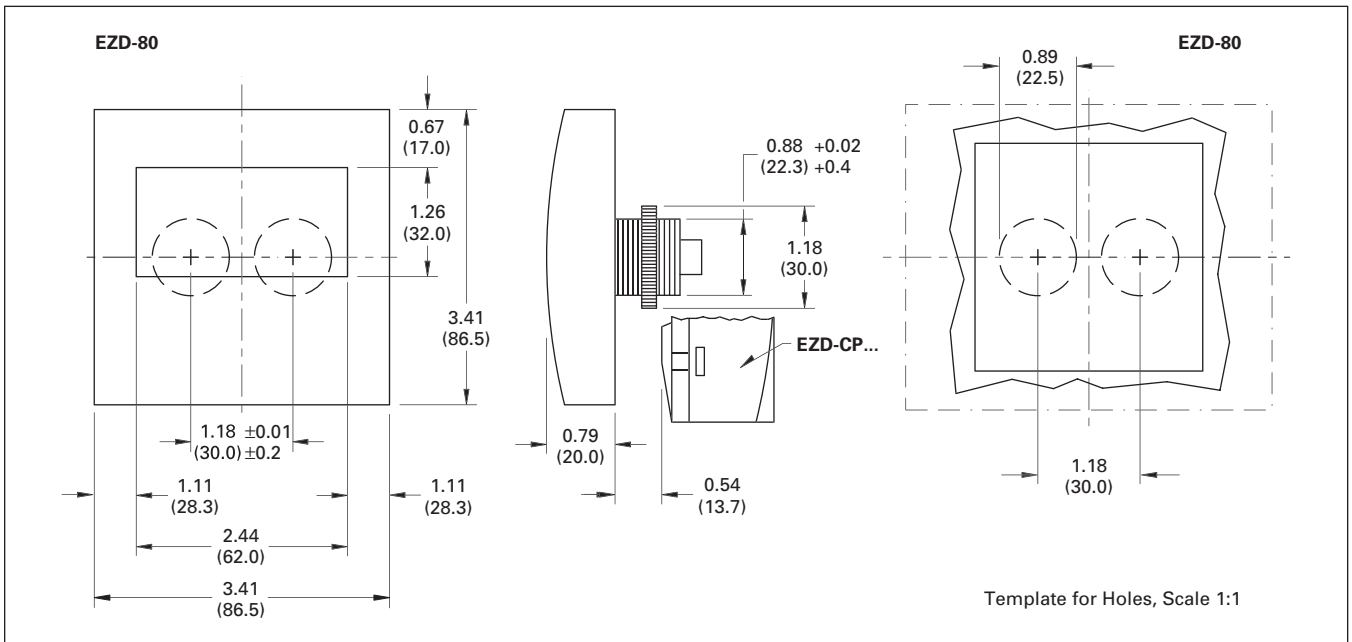

Figure 34.2-4. EZD-80 Series Dimensions in Inches (mm), Drawing Number MD05013005E

EZ 500/700/800/EZD Intelligent Relays

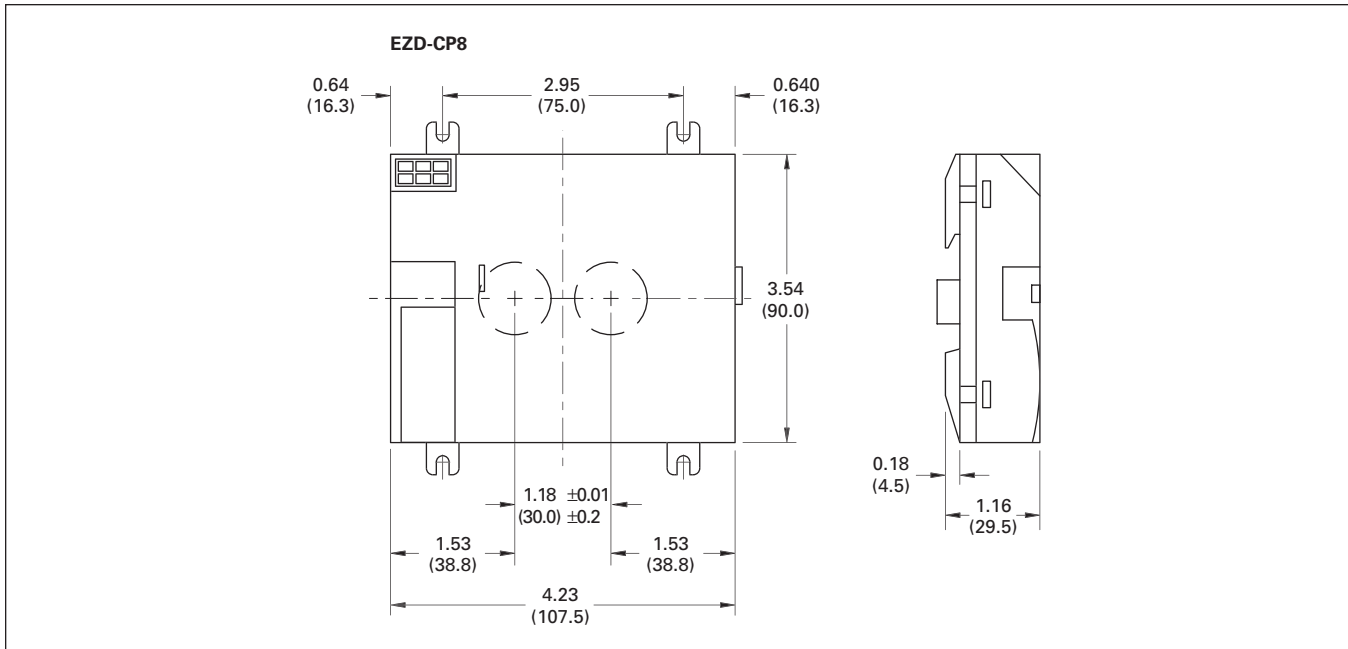

Figure 34.2-5. EVD-CP8 Series Dimensions in Inches (mm), Drawing Number MD05013006E

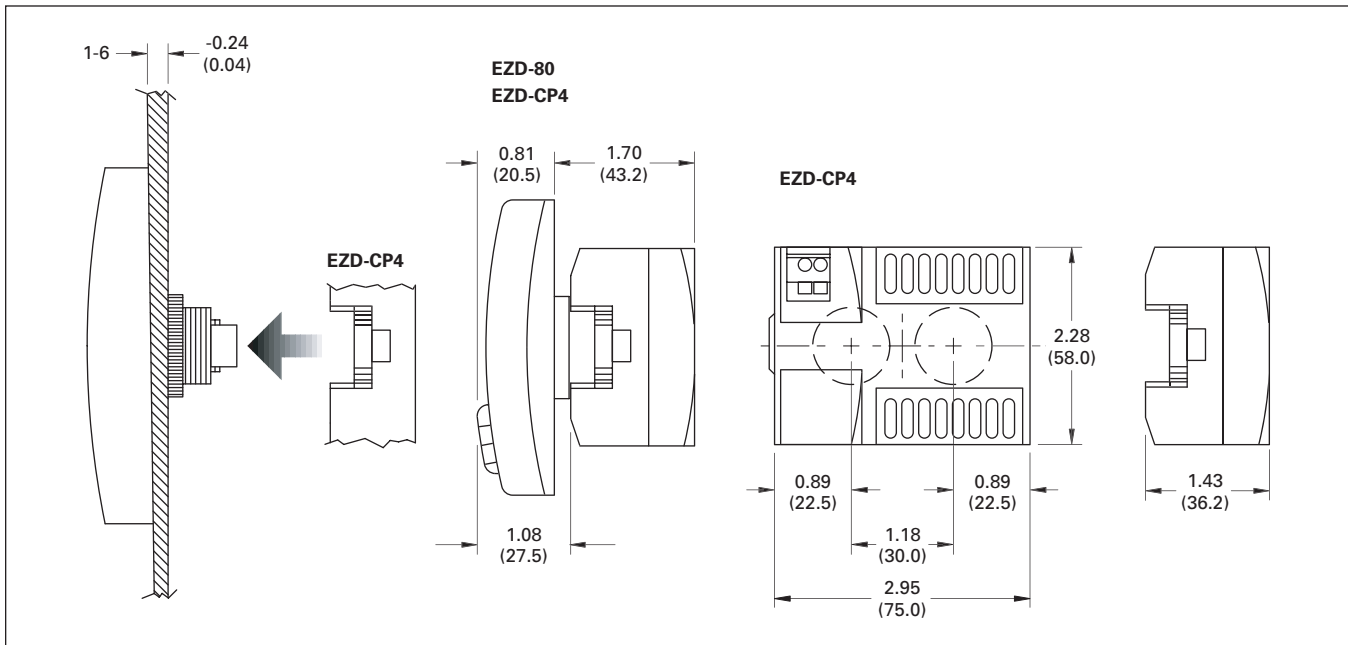

Figure 34.2-6. EVD-CP4, EVD-80 and EVD-CP4 Series Combined Dimensions in Inches (mm), Drawing Number MD013013E

EZD Controller I/O Modules

Product Selection

Table 34.2-13. EZD Controller I/O Modules

Description	Inputs			Outputs			Catalog Number
	110 – 240 Vac	24 Vdc	Analog	Relay	Transistor	Analog	
16 I/O	12	—	—	4	—	—	EZD-AC-R16 EZD-R16 EZD-RA17
16 I/O	—	12	4	4	—	—	
17 I/O	—	12	4	4	—	1	
16 I/O	—	12	4	—	4	—	EZD-T16 EZD-TA17
17 I/O	—	12	4	—	4	1	

Note: Analog inputs optional.

Technical Data and Specifications

Table 34.2-14. EZD Specifications

Type	EZD-AC-R16	EZD-R16	EZD-RA17	EZD-T16	EZD-TA17
Supply Voltage	Supply via EZD-CP8 Module				
Heat Dissipation	0.5 W	0.5 W	0.5 W	0.5 W	0.5 W
Continuous Current Outputs ①	8 A	8 A	8 A	0.5 A	0.5 A
Short-circuit Proof with Power Factor 1	Line protection B16, 600 A			—	—
Short-circuit Proof with Power Factor 0.7...0.7	Line protection B16, 900 A			—	—
Connection Cables	0.2 – 4.0 mm ² (AWG 22-12), Solid 0.2 – 2.5 mm ² (AWG 22-12), Flexible				
Degree of Protections	IP 20	IP 20	IP 20	IP 20	IP 20
RFI Suppression	EN 55011, EN 55022 Class B, IEC 61000-6-1,2,3,4				
Ambient Operating Temperature	-25 to 55°C	-25 to 55°C	-25 to 55°C	-25 to 55°C	-25 to 55°C
Transport and Storage Temperature	-40 to 70°C	-40 to 70°C	-40 to 70°C	-40 to 70°C	-40 to 70°C
Certification, Standards	EN 50178, IEC/EN 60947, UL, CSA				
Mounting	Snap Fitted to EZD-CP8 Module				

① Relay = 8 A (10 A to UL) with resistive load, 3 A with inductive load/transistor outputs = 0.5 A/24 Vdc, maximum 4 outputs switchable in parallel.

Dimensions

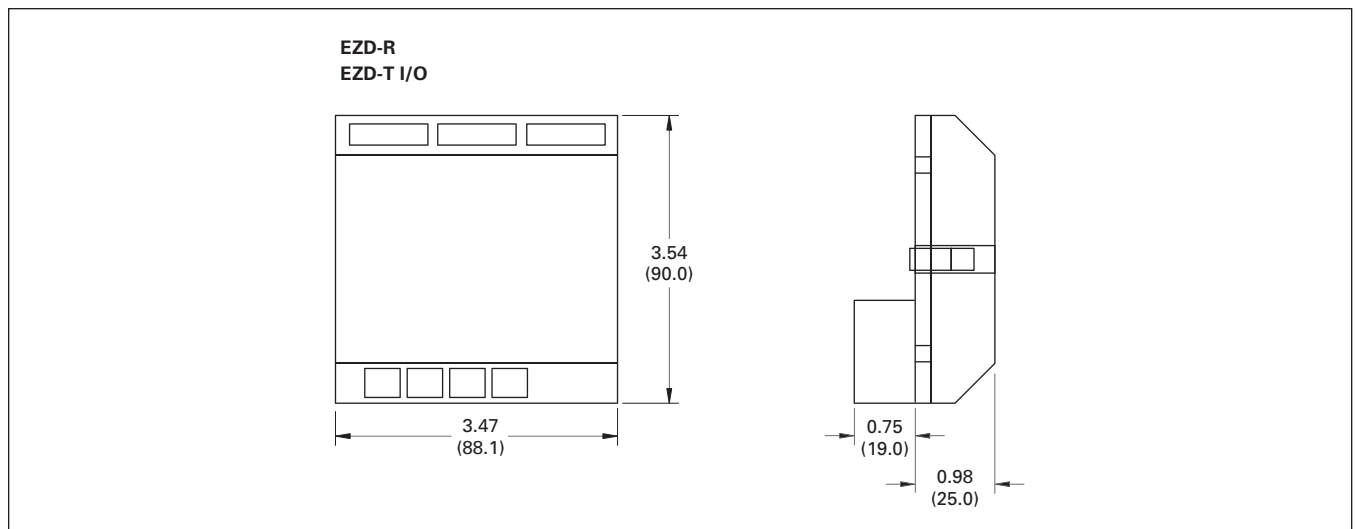
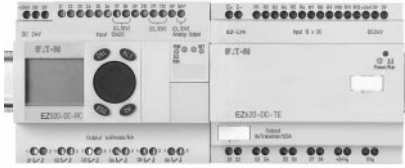

Figure 34.2-7. EZD-R/EZD-T I/O Module Dimensions in Inches (mm), Drawing Number MD05013007E

EZ/EZD Expansion Modules

EZ/EZD Expansion Modules



EZ/EZD Expansion Modules

Product Description

Expansion modules are available for increasing the input/output of the EZ700/800 and EZD intelligent relays to 24 inputs and up to 16 outputs. Expansion modules can be mounted directly to the EZ/EZD unit or up to 98 ft. (30 m) away using coupling module EZ200-EZ.

Product Selection

Table 34.2-15. EZ/EZD I/O Expansion Modules

Description	Inputs		Outputs		Catalog Number
	110 – 240 Vac	24 Vdc	RY	TRN	
2 I/O Expansion	—	—	2	—	EZ202-RE
18 I/O Expansion	12	—	6	—	EZ618-AC-RE
18 I/O Expansion	—	12	6	—	EZ618-DC-RE
20 I/O Expansion	—	12	—	8	EZ620-DC-TE
Coupling Module for Remote Mounting of Expansion Modules					EZ200-EZ

Technical Data and Specifications

Table 34.2-16. EZ Specifications

Type	EZ202-RE	EZ618-AC-RE	EZ618-DC-RE	EZ620-DC-TE	EZ200EZ
Supply Voltage	—	100 – 240 Vac	24 Vac	24 Vac	—
Heat Dissipation	1 W	10 VA	4 W	4 W	1 W
Continuous Current Outputs ^①	8 A	8 A	8 A	0.5 A	—
Short-circuit Proof with Power Factor 1	Line Protection B16, 600 A				—
Short-circuit Proof with Power Factor 0.7...0.7	Line Protection B16, 900 A				—
Connection Cables	0.2 – 4.0 mm ² (AWG 22-12), Solid 0.2 – 2.5 mm ² (AWG 22-12), Flexible				
Degree of Protections	IP 20	IP 20	IP 20	IP 20	IP 20
RFI Suppression	EN 55011, EN 55022 Class B, IEC 61000-6-1,2,3,4				
Ambient Operating Temperature	-25 to 55°C	-25 to 55°C	-25 to 55°C	-25 to 55°C	-25 to 55°C
Transport and Storage Temperature	-40 to 70°C	-40 to 70°C	-40 to 70°C	-40 to 70°C	-40 to 70°C
Certification, Standards	EN 50178, IEC/EN 60947, UL, CSA				
Mounting	On Top-hat Rail to DIN 50022, 35 mm or Screw Mounting with EZB4-101-GF1 Fixing Brackets				

^① Relay = 8A (10 A to UL) with resistive load, 3 A with inductive load/transistor outputs = 0.5 A/24 Vdc, maximum 4 outputs switchable in parallel.

Dimensions

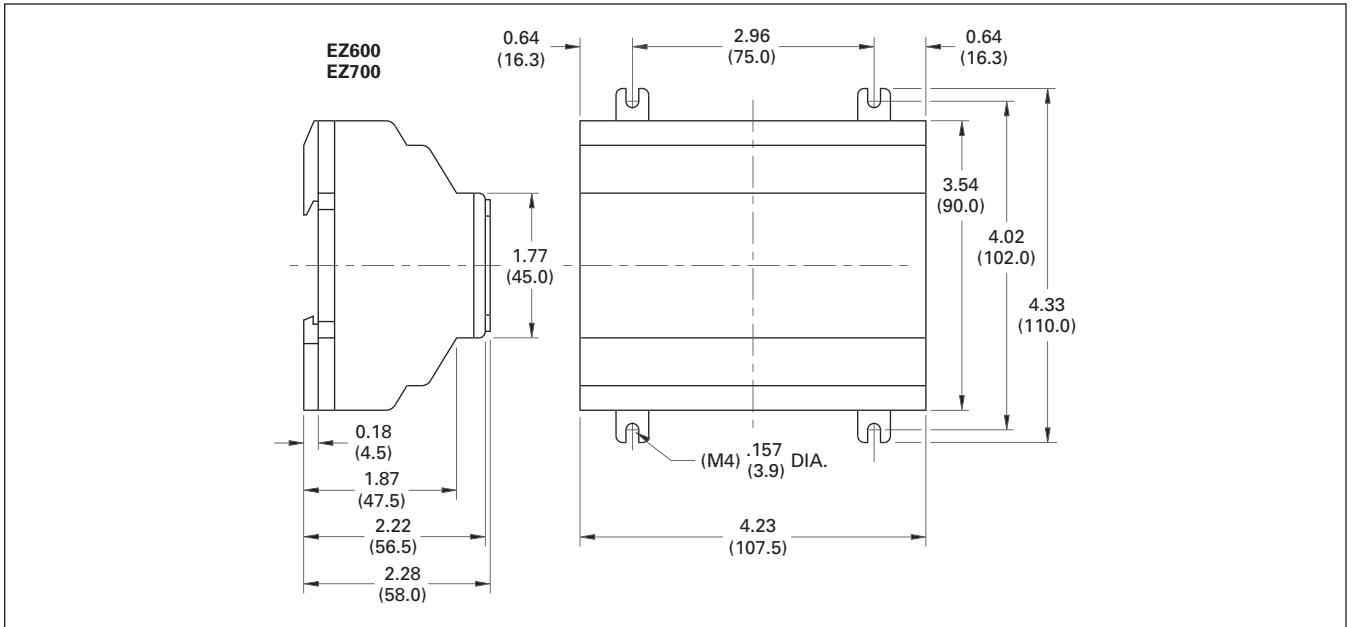

Figure 34.2-8. EZ600 and EZ700 Series Dimensions in Inches (mm), Drawing Number MD05013002E

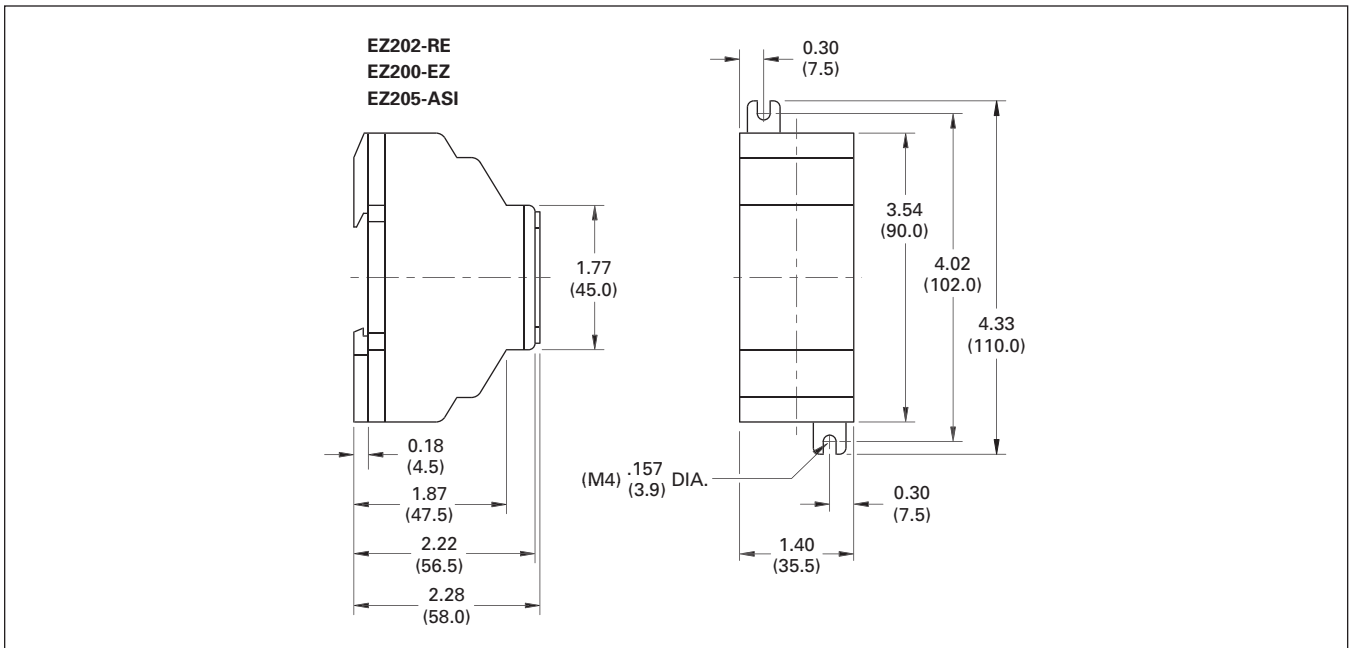

Figure 34.2-9. EZ202-RE/EZ200-EZ/EZ205-ASI Series Dimensions in Inches (mm), Drawing Number MD05013012E

EZ/EZD Communication Modules



EZ204-DP Communication Module

Product Description

Four modules are available for easily connecting to world-standard networks. The communication modules can be used with the EZ700/800 and EZD intelligent relays.

Available communication modules support:

- PROFIBUS-DP.
- AS-I (Actuator Sensor Interface) networks.
- CANopen.
- DeviceNet.

All modules act as a gateway and operate exclusively as a slave station on the network.

Product Selection

Table 34.2-17. EZ/EZD Communication Interface Modules

Description	Catalog Number
PROFIBUS-DP Slave Interface Module	EZ204-DP
AS-Interface Slave with 4 In and 4 Out Interface Module	EZ205-ASI
CANopen Interface Module	EZ221-CO
DeviceNet Slave Interface Module	EZ222-DN

Technical Data and Specifications

Table 34.2-18. EZ/EZD Specifications

Type	EZ204-DP	EZ205-ASI	EZ221-CO	EZ222-DN
Supply Voltage	24 Vdc	24 Vdc	24 Vdc	24 Vdc
Heat Dissipation	2 W	1 W	1 W	1 W
Connection Cables	0.2 – 4.0 mm ² (AWG 22-12), Solid 0.2 – 2.5 mm ² (AWG 22-12), Flexible			
Degree of Protections	IP 20	IP 20	IP 20	IP 20
RFI Suppression	EN 55011, EN 55022 Class B, IEC 61000-6-1,2,3,4			
Ambient Operating Temperature	-25 to 55°C	-25 to 55°C	-25 to 55°C	-25 to 55°C
Transport and Storage Temperature	-40 to 70°C	-40 to 70°C	-40 to 70°C	-40 to 70°C
Certification, Standards	EN 50178, IEC/EN 60947, UL, CSA			
Mounting	On Top-hat Rail to DIN 50022, 35 mm or Screw Mounting with EZB4-101-GF1 Fixing Brackets			

Dimensions

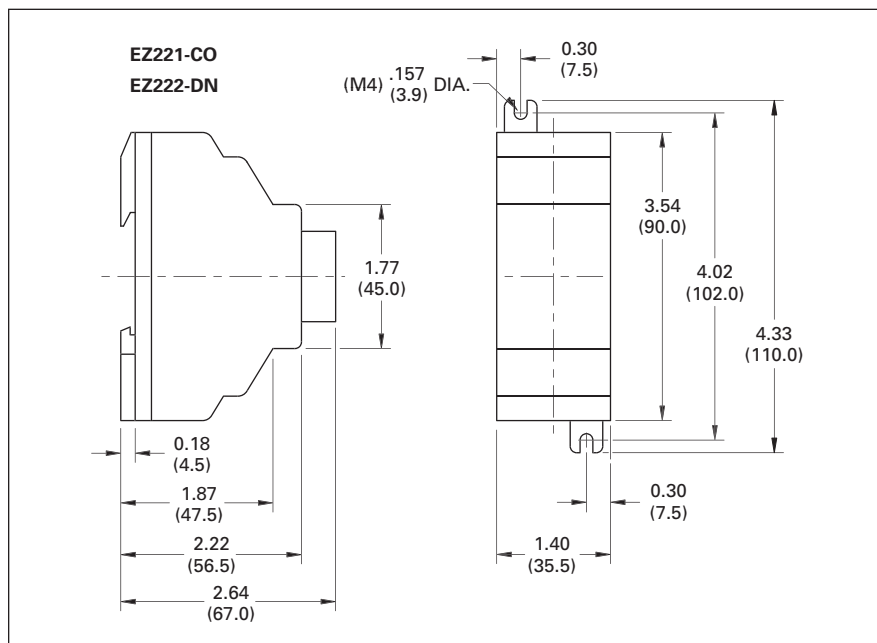

Figure 34.2-10. EZ221-CO/EZ222-DN Series Dimensions in Inches (mm), Drawing Number MD05013010E

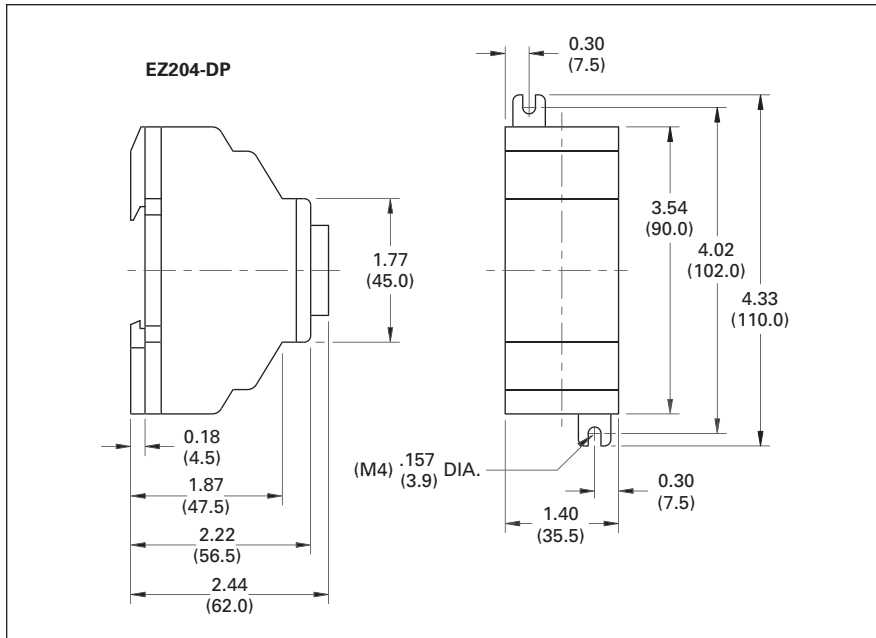

Figure 34.2-11. EZ204-DP Series Dimensions in Inches (mm), Drawing Number MD05013011E

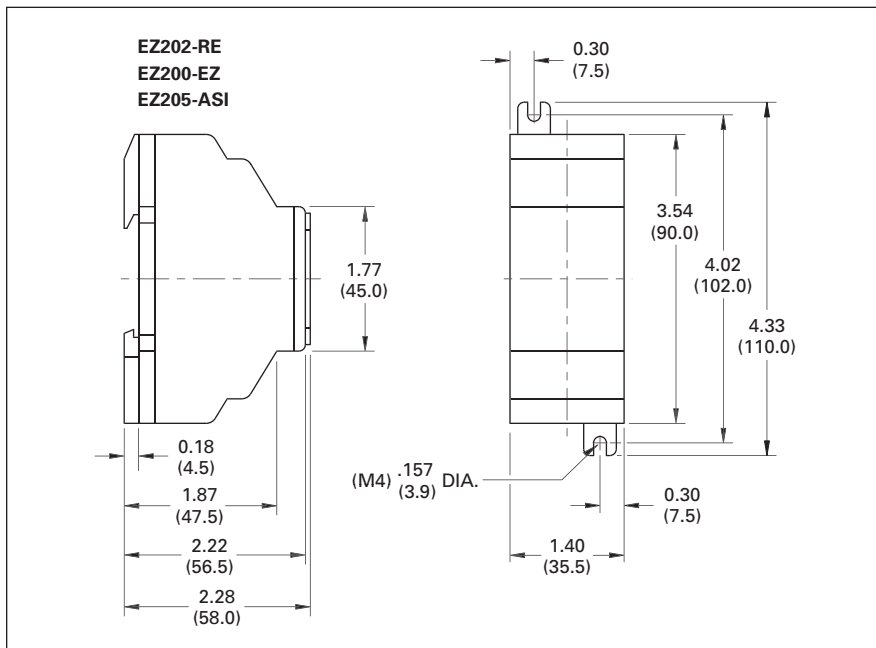

Figure 34.2-12. EZ202-RE/EZ200-EZ/EZ205-ASI Series Dimensions in Inches (mm), Drawing Number MD05013012E

EZ Software



EZSoft Software

Product Description

The EZSoft software is used to program all of the EZ and EZD controllers and displays. The Windows-based software provides straightforward circuit diagram input and editing and the diagrams can be displayed in the format desired. When EZ800 and EZD controllers are connected using EZ-NET, all connected devices can be accessed and their programs loaded from a single controller.

EZSoft includes an integrated offline simulation tool that allows users to test a circuit diagram before commissioning.

Product Selection

Table 34.2-19. EZ/EZD Software

Description	Catalog Number
Programming Software for EZ500/700/800 and EZD	EZSOFT

EZ/EZD Power Supplies

EZ/EZD Power Supplies

Product Selection

Table 34.2-20. EZ/EZD-CP8 Power Supplies

Description	Catalog Number
100 – 240 Vac Input to 12 Vdc at 20 mA/24 Vdc at 250 mA	EZ200-POW
100 – 240 Vac Input to 24 Vdc at 1.25 A	EZ400-POW

Technical Data and Specifications

Table 34.2-21. EZ Specifications

Type	EZ200-POW	EZ400-POW
Supply Voltage	100 – 240 Vac	100 – 240 Vac
Maximum Range	85 – 264 Vac	85 – 264 Vac
Output Voltage	24 Vdc ($\pm 3\%$)	24 Vdc ($\pm 3\%$)
Output Current (Rated Value)	0.25 A	1.25 A
Overcurrent Limitation Form	0.3 A	1.4 A
Short-circuit Proof (Secondary)	YES	YES
Overload Proof	YES	YES
Potential Isolation (Prim/Sec.)	YES, SELV, (to EN 600950, VDE 805)	YES, SELV, (to EN 600950, VDE 805)
Others	Additional Output Voltage 12 dc, 20 mA	Additional Output Voltage 12 dc, 20 mA
Connection Cables	0.2 – 4.0 mm ² (AWG 22-12), Solid 0.2 – 2.5 mm ² (AWG 22-12), Flexible	0.2 – 4.0 mm ² (AWG 22-12), Solid 0.2 – 2.5 mm ² (AWG 22-12), Flexible
Degree of Protections	IP 20	IP 20
RFI Suppression	EN 55011, EN 55022 Class B, IEC 61000-6-1, 2, 3, 4	EN 55011, EN 55022 Class B, IEC 61000-6-1, 2, 3, 4
Ambient Operating Temperature	-25 to 55°C	-25 to 55°C
Transport and Storage Temperature	-40 to 70°C	-40 to 70°C
Certification, Standards	EN 50178, IEC/EN 60947, UL, CSA	EN 50178, IEC/EN 60947, UL, CSA
Mounting	On Top-hat Rail to DIN 50022, 35 mm or Screw Mounting with EZB4-101-GF1 Fixing Brackets	

Dimensions

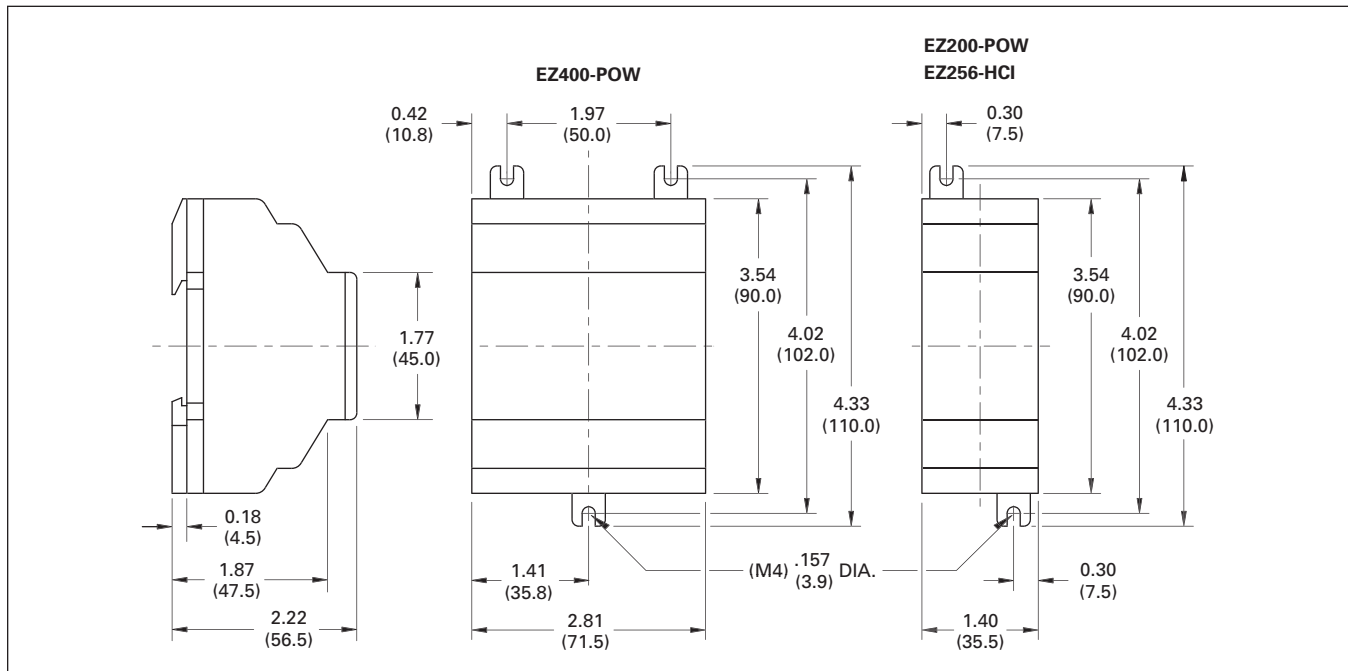

Figure 34.2-13. EZ200-POW/EZ256-HCI and EZ400-POW Series Dimensions in Inches (mm), Drawing Number MD05013004E

EZ/EZD Accessories



EZ700/500 Panel Window and Mounting Kit

Product Selection

Table 34.2-22. EZ/EZD Memory Storage Modules

Description	Catalog Number
EZ500/700 32K Memory Storage Module	EZ-M-32K
EZ800/EZD 256K Memory Storage Module	EZ-M-256K

Table 34.2-23. EZ/EZD Programming Cables

Description	Catalog Number
EZ500/700 to PC Cable	EZ-PC-CAB
EZ800/EZD to PC Cable	EZ800-PC-CAB

Table 34.2-24. EZ/EZD Cables and Connectors

Description	Catalog Number
EZ500/700 to EZD-CP4 Communication Cable, 5 m	EZD-CP4-500-CAB5
EZ800 to EZD-CP8 Communication Cable, 2 m	EZD-800-CAB
EZ800 to EZD-CP8 Communication Cable, 5 m	EZD-800-CAB5
EZ800 to EZD-CP4 Communication Cable, 5 m	EZD-CP4-800-CAB5
EZ800/EZD EZ-NET Cable, 0.3 m	EZ-NT-30
EZ800/EZD EZ-NET Cable, 0.8 m	EZ-NT-80
EZ800/EZD EZ-NET Cable, 1.5 m	EZ-NT-150
EZ800/EZD Network Termination Resistor, 2/Pack	EZ-NT-R
EZ800/EZD EZ-NET Cable (Cable Only, No Connectors, See EZ-NT-RJ45), 100 m	EZ-NT-CAB
RJ45 Network Connectors for EZ-NET Cable (EZ-NT-CAB), 10/Pack	EZ-NT-RJ45

Table 34.2-25. EZ/EZD Miscellaneous Parts

Description	Catalog Number
EZ500 Relay Simulator	EZ412-DC-SIM-NA
EZ500 Panel Window	EZSKF-FF4
EZ700/800 Panel Window	EZSKF-FF6
EZ500/700/800 Panel Window Mounting Kit to Front Mount Units	EZSKF-HA
EZ/EZD Panel Mount Brackets, 9/Pack	EZB4-101-GF1
EZ/EZD Grounding Kit	EZB4-102-KS1
EZD Display DIN Rail Mount Kit	EZD-TS144
EZD Display Protective Membrane Cover	EZD-XM-80
EZD Display Protective Plastic Cover	EZD-XS-80
EZ/EZD 6 Channel Noise Suppression Adapter	EZ256-HCI
EZ/EZD Spare Interface Connector, Base to Expander	EZ-LINK-DS
EZSoft Configuration Software	EZSOFT
EZ Starter Kit (Includes EZ512-DC-RC, EZ-PC-CAB, EZ412-DC-SIM-NA, EZSoft)	EZSTARTKIT1

Dimensions

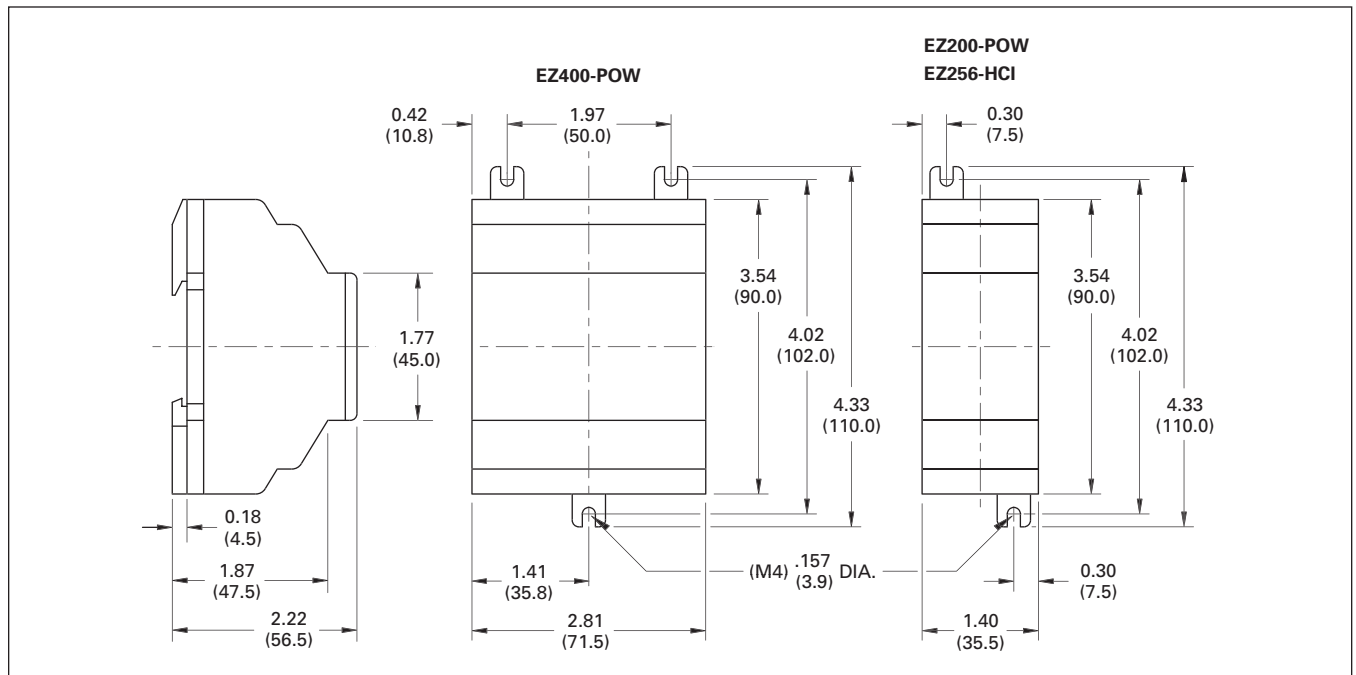

Figure 34.2-14. EZ200-POW/EZ256-HCI and EZ400-POW Series Dimensions in Inches (mm), Drawing Number MD05013004E

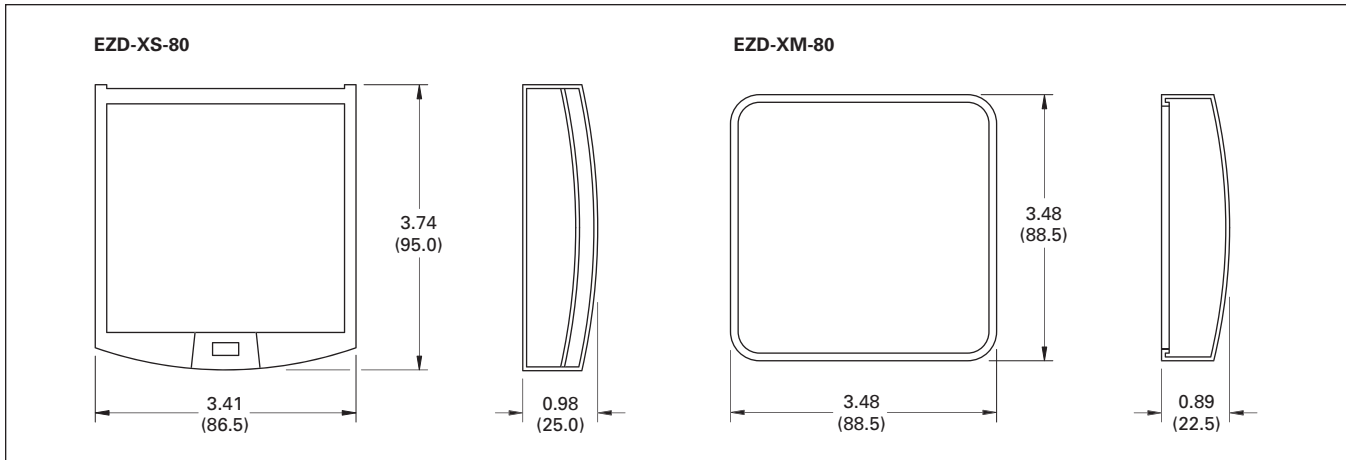

Figure 34.2-15. EZD-XS-80 and EZD-XM-80 Series Dimensions in Inches (mm), Drawing Number MD05013009E

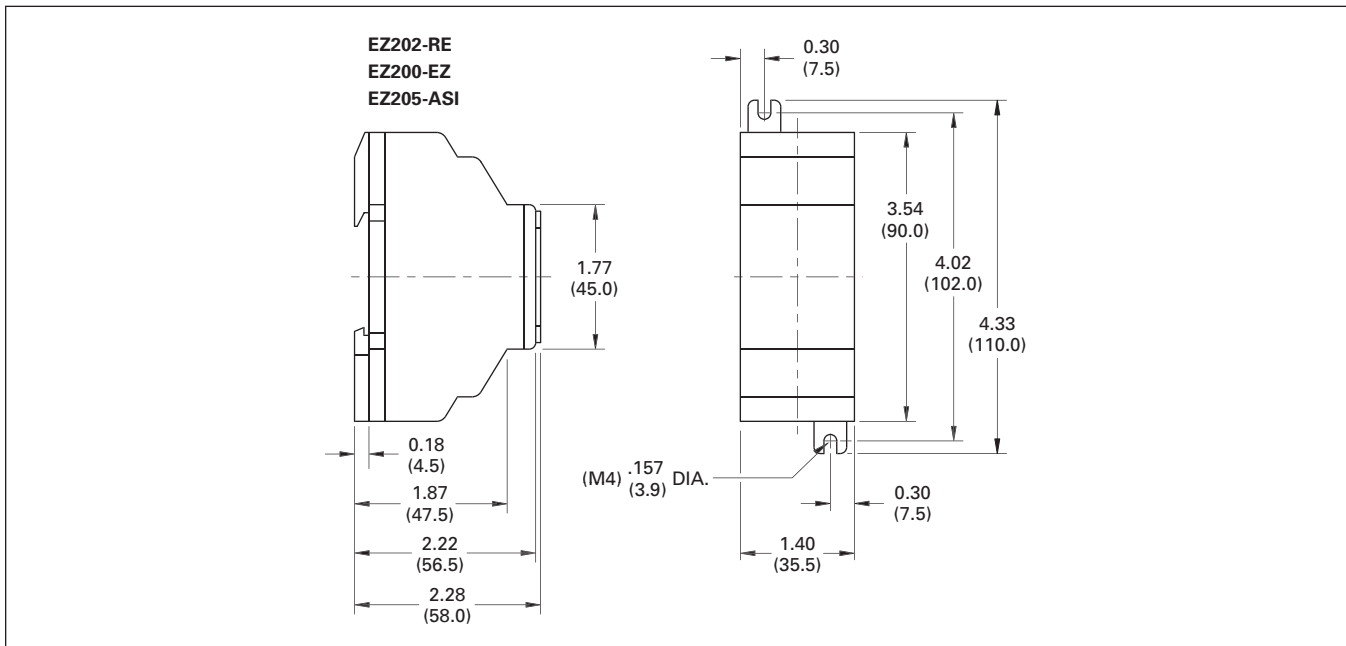

Figure 34.2-16. EZ202-RE/EZ200-EZ/EZ205-ASI Series Dimensions in Inches (mm), Drawing Number MD05013012E

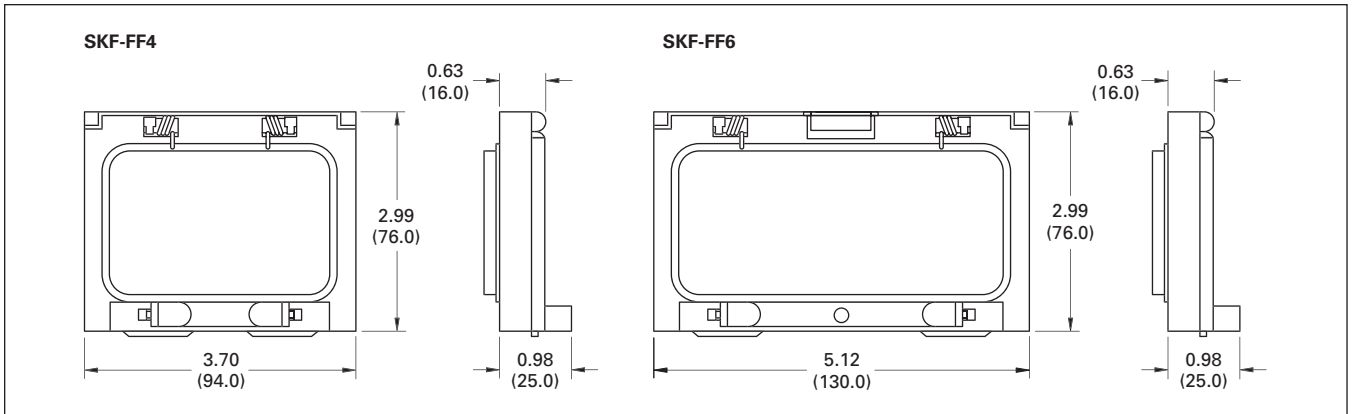

Figure 34.2-17. EZSKF-FF4 and EZSKF-FF6 Series Dimensions in Inches (mm), Drawing Number MD05013014E

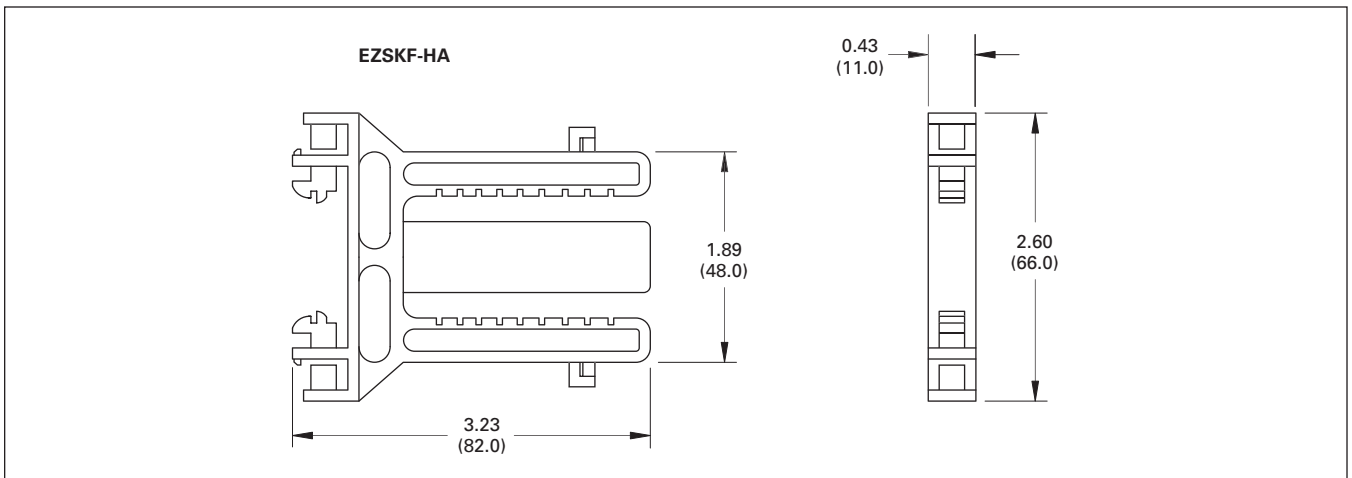

Figure 34.2-18. EZSKF-HA Series Dimensions in Inches (mm), Drawing Number MD05013015E

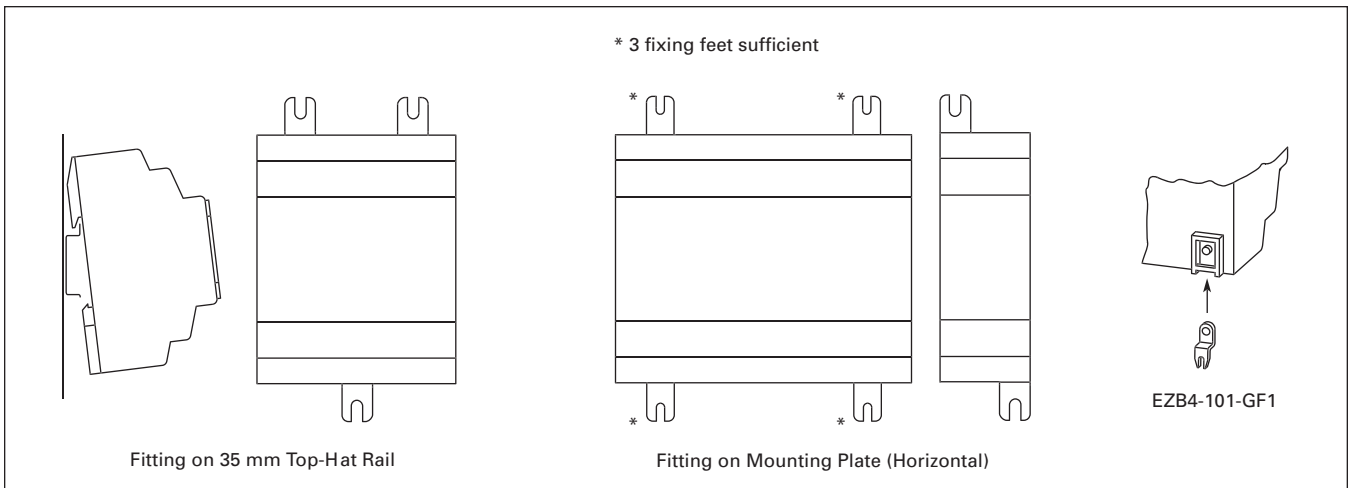

Figure 34.2-19. EZB4-101-GF1 Series

EZ/EZD Accessories

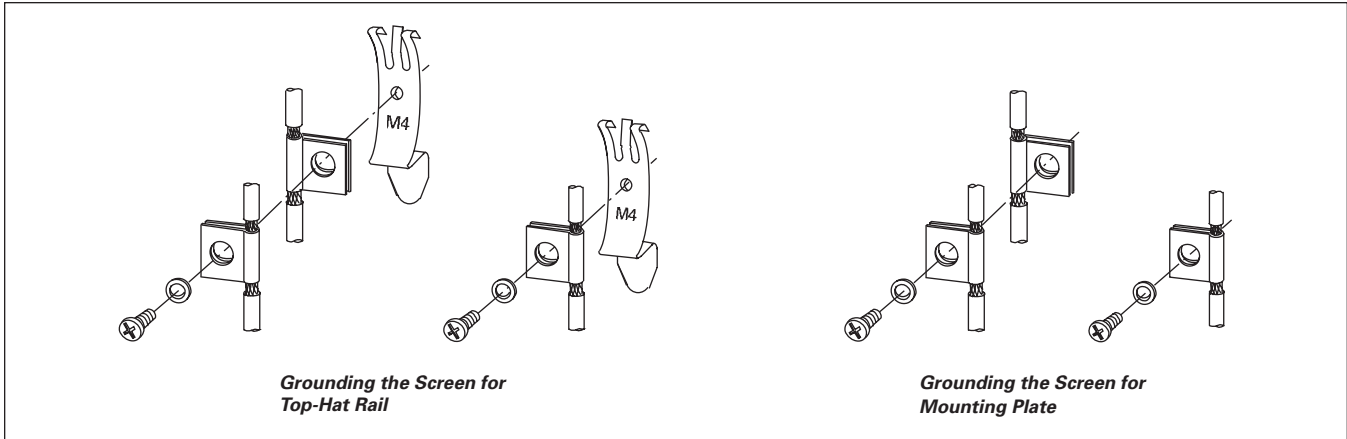

Figure 34.2-20. EZB4-102-KS1 Series

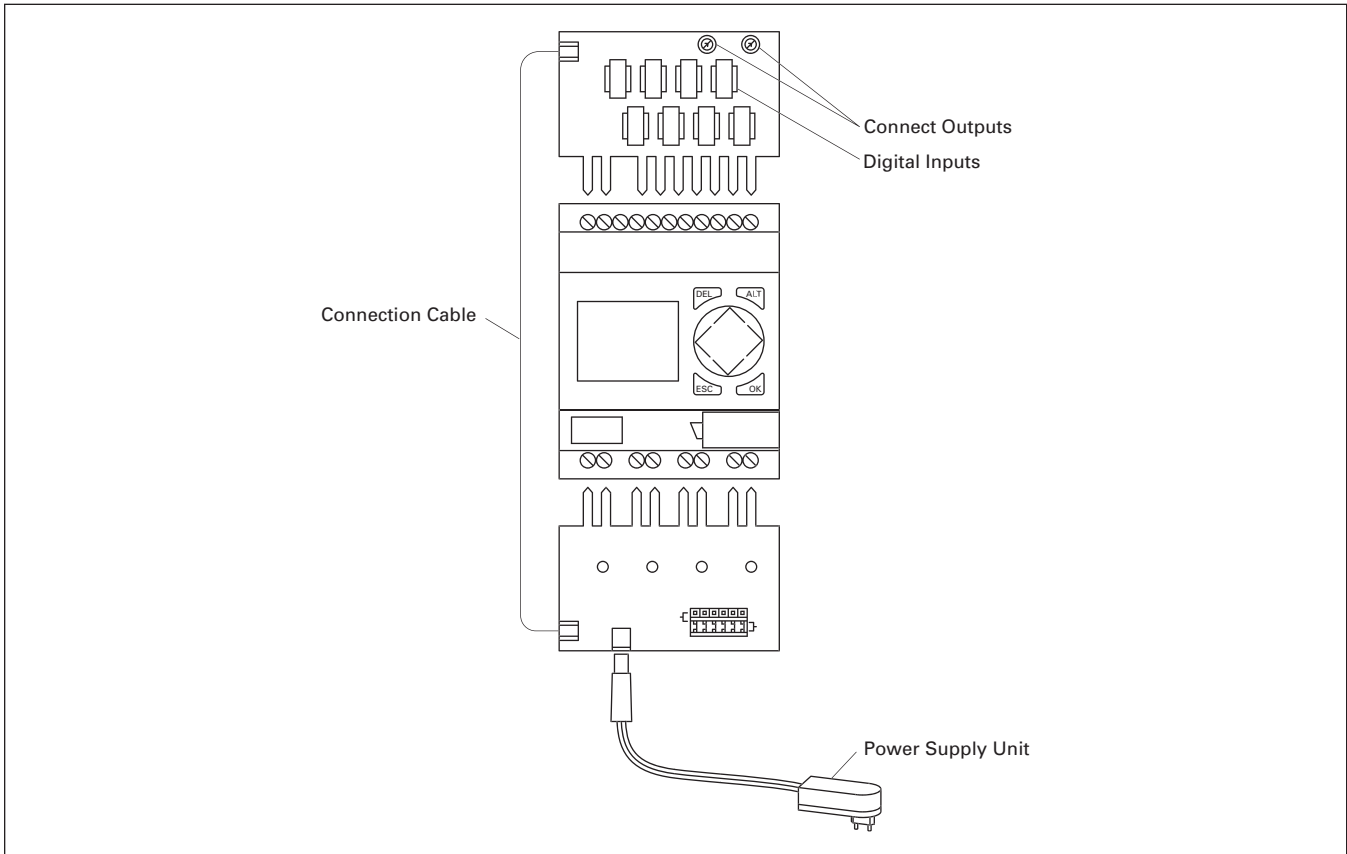

Figure 34.2-21. EZ412-DC-SIM-NA Series

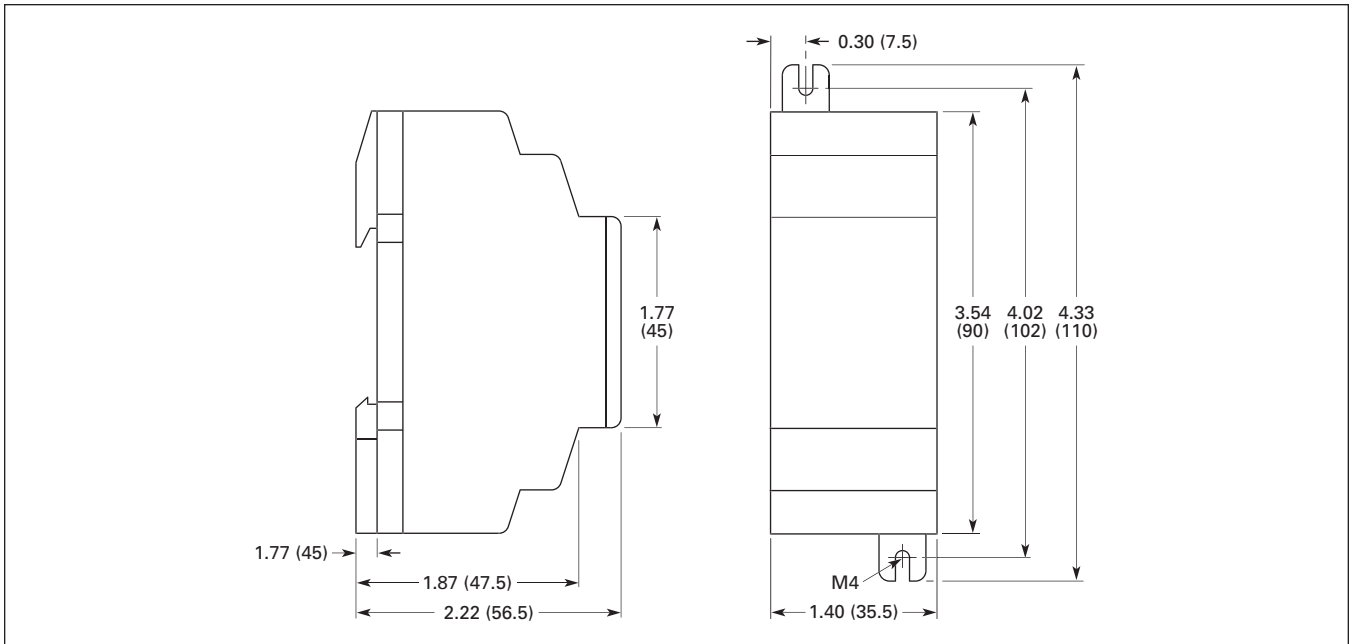

Figure 34.2-22. EZ256-HCI Dimensions in Inches (mm)

Wiring Diagram

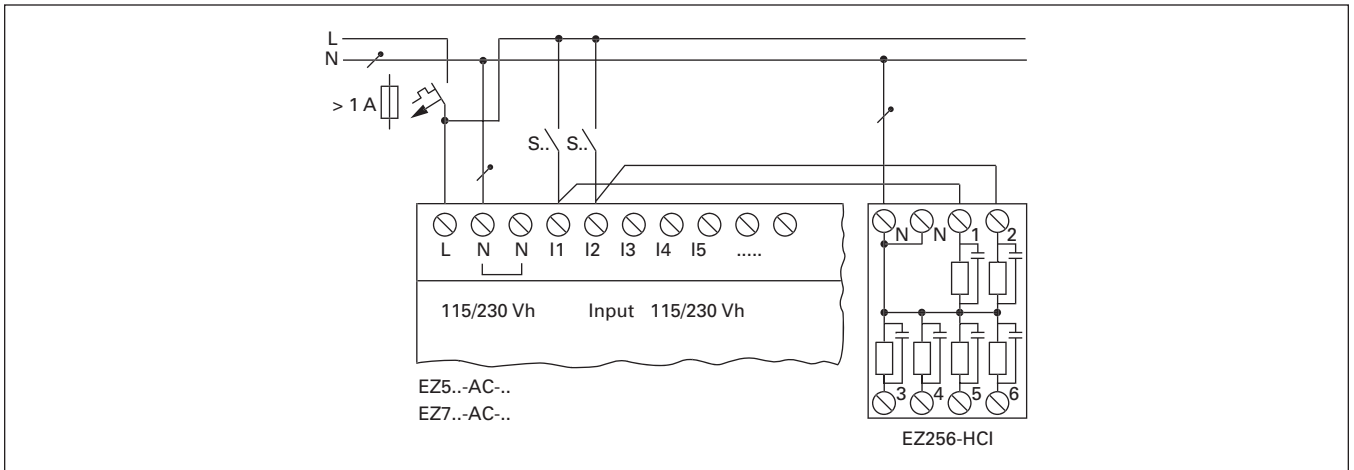

Figure 34.2-23. EZ256-HCI Wiring Diagram

PROFIBUS is a registered trademark of PROFIBUS International. Modbus is a registered trademark of Modicon, a division of Schneider Electric Industries SA. UL and cUL are federally registered trademarks of Underwriters Laboratories Inc. Cutler-Hammer is a federally registered trademark of Eaton Corporation. Siemens is a federally registered trademark of Siemens AG. NEMA is the registered trademark and service mark of the National Electrical Manufacturers Association. Windows is a registered trademark of Microsoft Corporation. Windows is a registered trademark of Microsoft Corporation. CSA is a registered trademark of the Canadian Standards Association.

This page intentionally left blank.